

MITSUBISHI

A870GOT Graphic Operation Terminal

User's Manual

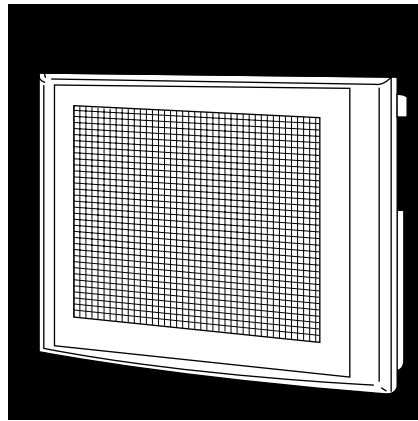

GRAPHIC OPERATION TERMINAL

800

Series



Mitsubishi Graphic Operation Terminal

● SAFETY PRECAUTIONS ●

(Read these precautions before using.)

When using Mitsubishi equipment, thoroughly read this manual and the associated manuals introduced in this manual. Also pay careful attention to safety and handle the module properly.

These precautions apply only to Mitsubishi equipment. Refer to the CPU module use's manual for a description of the PC system safety precautions.

These ● SAFETY PRECAUTIONS ● classify the safety precautions into two categories: "DANGER" and "CAUTION".



DANGER

Procedures which may lead to a dangerous condition and cause death or serious injury if not carried out properly.



CAUTION

Procedures which may lead to a dangerous condition and cause superficial to medium injury, or physical damage only, if not carried out properly.

Depending on circumstances, procedures indicated by  CAUTION may also be linked to serious results. In any case, it is important to follow the directions for usage.

Store this manual in a safe place so that you can take it out and read it whenever necessary. Always forward it to the end user.

[DESIGN PRECAUTIONS]



DANGER

- A malfunction in the GOT main module, communication module, bus connection module, communication cable, and bus connection cable may keep the output ON or OFF. Add a circuit to externally monitor the output which could lead to a serious accident.

An accident may occur by a false output or a malfunction.

- If a communication error (including by a disconnected cable) occurs while the monitor is running on the GOT, the communication between the GOT and the PC CPU is interrupted, and the GOT stops running.

When using the bus connection: PC CPU goes down and the GOT stops running.

When not using the bus connection: GOT is not operational.

For a system configuration using a GOT, design the system such that the crucial switching to the system is performed by the equipment other than the GOT with the assumption that a communication error could occur in the GOT.

An accident may occur by a false output or a malfunction.

! DANGER

- Regardless the touch-switch function is set or not, when multiple touch switches (two places or more) are pressed simultaneously as shown in the following diagram, the GOT is designed to execute a pre-defined operation of the touch switch if a touch switch function is defined at the fourth vertex of the rectangle.

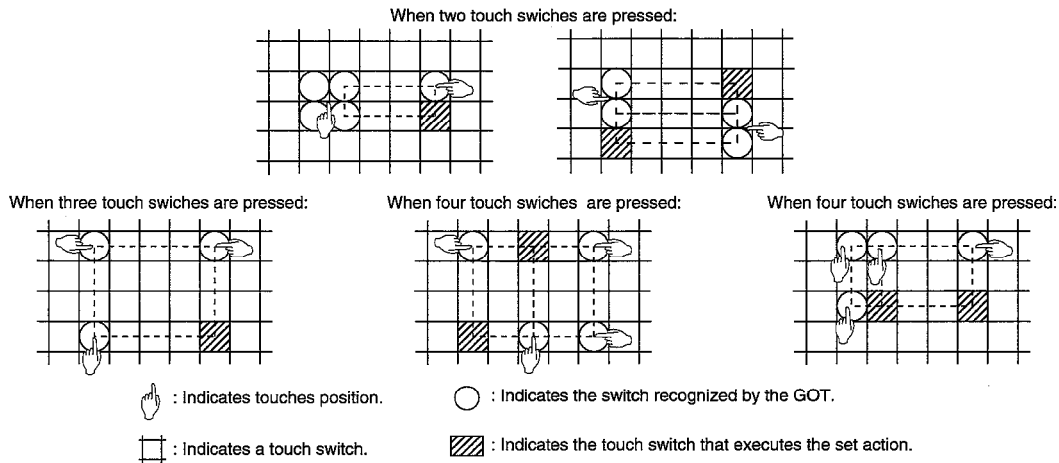

When multiple touch switches are pressed simultaneously under the conditions described above, make sure that the system works safely by carefully considering the location of each touch switch function and adding an interlock circuit to the write device using a sequence program, etc.

A malfunction might cause a breakdown, accident, or damage to the machine.

! CAUTION

- Do not bunch the communication cables and bus connection cables with the main circuit or power wires, or install them close to each other. They should be installed 100 mm (3.9 inch) or more from each other, Failure to do so may result in noise that would cause malfunctioning.

[INSTALLATION PRECAUTIONS]

! CAUTION

- Make sure to switch all phases of the external GOT's power supply off before installing or removing the GOT main module to/from the base.
If you do not switch off the external power supply, it will cause failure or malfunction of the module.
- Make sure to switch all phases of the external GOT's power supply off before mounting or removing the power supply module, communication module, bus connection module, optional module, memory cassette, and memory card to/from the GOT main module.
If you do not switch off the external power supply, it will cause failure or malfunction of the module.
- Make sure to switch all phases of the external GOT and PC CPU side power supply off before connecting the communication cable and bus connection cable to the communication module and bus connection module.
If you do not switch off the external power supply, it will cause failure or malfunction of the module.

 **CAUTION**

- Use the GOT in the environment given in the general specifications of the GOT User's Manual. Using the GOT outside the range of the general specifications may result in electric shock, fire or malfunctioning, or may damage or degrade the module.

- Tighten the attachment screws for installing the GOT main module to the base within the range of specified torque.

If the attachment screws are loose, it may result in fallout, short circuits, or malfunctions.

Tightening the attachment screws too far may cause damages to the screws and/or the module, resulting in fallout, short circuits, or malfunctions.

- When using a bus connection, bus connection cables should be securely connected to the connectors of the bus connection module, bus connector conversion module, and base unit. After connecting the connector, check to make sure they are securely tightened and not loose. Defective contact could cause a false input and output.

- The communication cable should be connected securely to the connector on the communications module and PC CPU side. After connecting the connector, check to make sure they are securely tightened and not loose. Defective contact could cause a false input and output.

- When the power supply module, communication module, bus connection module, and the optional module are installed to the GOT main module, attach them to the GOT attachment part by aligning to the screw guide, then tighten the module fixed screws within the range of specified torque.

If the module fixed screws are loose, it may result in fallout, short circuits, or malfunctions.

Tightening the module fixed screws too far may cause damages to the screws and/or the module, resulting in fallout, short circuits, or malfunctions.

- Make sure the memory cassette and memory card are installed securely in their connector. After connecting the connector, check to make sure they are securely tightened and not loose. Defective contact could cause malfunctions.

[WIRING PRECAUTIONS]

 **DANGER**

- Make sure to switch all phases of the external GOT's power supply off before beginning wiring work. If you do not switch off the external power supply, it will cause electric shock, malfunction, or damage to the module.

 **CAUTION**

- The FG and LG terminals should always be grounded using the class-3 or higher grounding designed specially for the GOT. Failure to ground these terminals may cause electric shock or malfunctions.
- When wiring the GOT's power supply module, check the rated voltage and terminal layout of the wiring, and make sure the wiring is done correctly. Connecting a power supply that differs from the rated voltage or wiring it incorrectly may cause fire or failure.
- Tighten the GOT power supply module's terminal screws within the range of specified torque. If the terminal screws are loose, it may result in fallout, short circuits, or malfunctions. Tightening the terminal screws too far may cause damages to the screws and/or the module, resulting in fallout, short circuits, or malfunctions.
- When wiring the power supply module of the GOT, be careful that foreign objects, such as chips from the braided shield and wiring scraps, don't get caught in the GOT main module, power supply module, communication module, bus connection module, and the optional module.
These can cause fire, failure or malfunctions.

[PRECAUTIONS WHEN PERFORMING THE TEST OPERATION]

 **DANGER**

- Read the manual carefully and fully understand the operation before the test operation (ON/OFF of bit devices, modifying current value of a word device, modifying timer/counter setting, modifying the current value, or modifying the current value of a buffer memory) of the user created monitor screen, system monitor, special module monitor, and circuit monitor.
In addition, never modify data in a test operation to a device which performs a crucial operation to the system.
It may cause an accident by a false output or malfunction.

[STARTING AND MAINTENANCE PRECAUTIONS]

 **DANGER**

- Do not touch the terminals while the power is on. Doing so may cause electric shock or malfunction.
- Make sure to switch all phases of the external GOT's power supply off before cleaning or re-tightening terminal screws. If you do not switch off the external power supply, it will cause electric shock. If the terminal screws are loose, it may result in fallout, short circuits, or malfunctions. Tightening the terminal screws too far may cause damages to the screws and/or the module, resulting in fallout, short circuits, or malfunctions.

 **CAUTION**

- Never disassemble or modify the GOT main module, power supply module, communication module, optional module, memory cassette, and memory card. This may cause failure, malfunctions, injury, and/or fire.
- Don't touch the conductive parts and electronic parts of the GOT main module, power supply module, communication module, optional module, or the memory cassette directly. This may cause the module to malfunction or failure.
- Because they are made of resin, don't drop or give a strong shock to the GOT main module, power supply module, communication module, optional module, and memory cassette. This may cause failure.

[DISPOSAL PRECAUTIONS]

 **CAUTION**

- When disposing of this product, treat it as industrial waste.

[PRECAUTIONS WHEN REPLACING THE BACKLIGHT]

 **DANGER**

- Make sure to switch all phases of the external GOT's power supply off (When the GOT is connected to a bus, turn off the PC's CPU power) before replacing the backlight, and first remove the GOT main module from the panel. If you do not switch off the external power supply, it will cause electric shock. If left in the panel, the GOT could fall and cause an injury.

 **CAUTION**

- Do not touch the GOT's circuit board or electronic components when replacing the backlight. Doing so could cause failure or malfunction.
- Be sure to take the following precautions when replacing the TFT backlight (A8GT-70LTT).
 - Wear gloves or finger socks when replacing the backlight. This may cause an injury.
 - Replace the backlight after waiting 5 or more minutes after turning the GOT's power off. The heat from the backlight can cause burns.

[PRECAUTIONS WHEN DISPOSING THE BACKLIGHT]

 **CAUTION**

- When disposing the backlight, treat it as industrial waste.

Revisions

* The manual number is noted at the lower left of the back cover.

Print Date	*Manual Number	Revision
Feb. 1996	IB (NA)-66628-A	First printing
Apr. 1996	IB (NA)-66628-B	Correction: Section 1.1, 1.2, 1.3,1.4, 2.1, 2.5.1, 2.5.3, 2.5.4, 2.7, 2.8, 2.9, 3.3, 5.1.2, 5.4.2, 7.8, 9.2, 10.2 Addition: Section 2.2.2, 3.1, 3.2.1, 3.2.2, 5.1.1, 5.2.1, 10.3, Chapter 13
Jan. 1997	IB (NA)-66628-C	Correction: Section 1.1, 2.5.2, 5.3.3, 13.1.3 Addition: SAFETY PRECAUTIONS [DESIGN PRECAUTIONS] Section 1.5, 3.2.2
Mar. 1997	IB (NA)-66628-D	Correction: Section 1.1, 3.4 Addition: Chapter 2 System configuration when connecting MELSEC-FX/Omron PLC/microcomputer, Chapter 12 A7GT-BUSS/A7GT-BUS2S, Section 3.2, 3.3, 3.5, Appendix 1

This manual does not imply guarantee or implementation right for industrial ownership or implementation of other rights. Mitsubishi Electric Corporation is not responsible for industrial ownership problems caused by use of the contents of this manual.

Introduction

Thank you for purchasing the Mitsubishi Graphic Operation Terminal.

Before using the equipment, please read this manual carefully to develop full familiarity with the functions and performance of the graphic operation terminal you have purchased, so as to ensure correct use.

Please forward a copy of this manual to the end user.

Contents

1. Overview	1- 1 to 1 -14
1.1 Features	1- 1
1.2 Structure and Guide to the Use of This Manual	1- 8
1.3 Abbreviations and Symbols Used in This Manual	1-10
1.4 Parts Supplied with This Product	1-13
1.5 Precautions When Installing the ROM_BIOS/OS	1-14
2. System Configuration	2- 1 to 2-38
2.1 Equipment Required for A870G0T	2- 1
2.2 System Configuration When Creating Monitor Screens	2- 2
2.3 System Configuration Used for Data Transmission, Debugging, and Document Creation	2- 3
2.3.1 System configuration	2- 3
2.3.2 RS-232C cables used for data transmission	2- 3
2.4 System Configuration When Monitoring Through CPU Direct Connection	2- 4
2.5 System Configuration and Precautions When Monitoring Through a Bus Connection	2- 5
2.6 System Configuration and Precautions When Monitoring Through a Calculator Link Connection (RS-422 Communication)	2- 6
2.6.1 System configuration	2- 6
2.6.2 Precautions regarding the system configuration	2- 7
2.6.3 Hardware settings for the calculator link module	2- 9
2.6.4 Hardware settings for the serial communications module	2-10
2.7 System Configuration When Monitoring Through a MELSECNET Connection (Connected to a Data Link System)	2-11
2.8 System Configuration When Monitoring Through a MELSECNET Connection (Connected to a Network System)	2-12
2.9 System Configuration When Connecting to the MELSEC-FX Series	2-13
2.9.1 When connected to the FX ₀ , FX _{0N} , FX _{0S} , and FX _{2N} series	2-13
2.9.2 When connected to the FX ₁ and FX ₂ , FX _{2c} series	2-14
2.9.3 System configuration precaution items	2-14
2.10 System Configuration When Connecting to the Omron PLC	2-15
2.10.1 System configuration when connected to the C200H and C200HS	2-15
2.10.2 System configuration when connecting to the C200H α series	2-19
2.10.3 System configuration when connecting to the CQM1	2-22
2.10.4 System configuration when connecting to the C1000H and C2000H	2-25
2.10.5 System configuration when connected to CV1000	2-28
2.11 System Configuration When Connecting to the Microcomputer	2-30
2.11.1 Overview	2-30
2.11.2 System configuration	2-30
2.11.3 About the connection cables	2-31

2.11.4	Transmission specification	2-32
2.11.5	Communication commands	2-33

3. Specifications	3- 1 to 3- 9
--------------------------	---------------------

3.1	General Specifications	3- 1
3.2	Performance Specifications	3- 2
3.2.1	GOT main module	3- 2
3.2.2	Power supply module	3- 3
3.3	Supported CPU	3- 4
3.4	Monitor Functions that can be Used with Each Connection Method	3- 6
3.6	Table of Component Equipment Modules	3- 7

4. Names of Parts and Their Settings	4- 1 to 4- 2
---	---------------------

4.1	GOT Main Module	4- 1
4.2	Power Supply Module	4- 2

5. Handling Component Equipment Modules	5- 1 to 5-17
--	---------------------

5.1	Protective Sheets	5- 1
5.1.1	Types of protective sheets	5- 1
5.1.2	Attachment procedures	5- 1
5.2	Memory Cassettes	5- 2
5.2.1	Types of memory cassettes	5- 2
5.2.2	Installing and removing memory cassettes	5- 2
5.3	Memory Cards	5- 4
5.3.1	Types of memory cards that can be used	5- 4
5.3.2	Installing and removing the memory card	5- 4
5.3.3	When and how to replace the battery	5- 6
5.4	Installing the Communications Modules	5- 7
5.4.1	Installing the serial communications module	5- 7
5.4.2	Installing the bus connection module	5- 8
5.4.3	Installing a data link module	5- 9
5.4.4	Installing a network module	5-12
5.5	Installing a Power Supply Module	5-16
5.6	Installing a Printer Interface Module/External I/O Interface Module	5-17

6. Procedures to Prepare for Starting Operation	6- 1
--	-------------

7. Operating Utility Functions	7- 1 to 7- 13
---------------------------------------	----------------------

7.1	Table of Utility Functions	7- 1
7.2	Procedures to Prepare for Running the Various Functions	7- 2
7.3	Selecting Functions on the Utility Menu Screen	7- 3
	(Adjusting the Screen Brightness — Brightness Adjustment)	
	(Selecting the Screen Message Display — Message Display Selection)	
7.4	Monitoring PC CPU Device Data on a Dedicated Screen (System Monitor)	7- 4

7.5	Monitoring the Special Functions Module Buffer Memory on a Dedicated Screen (Special Functions Module Monitor)	7- 5
7.6	Copying Monitor Data Between the Internal Memory and Memory Card (Screen Copy)	7- 6
7.7	Entering GOT Usage Environment Settings (Setup)	7- 7
7.8	Self-Test of the GOT Main Module Hardware (Self-Test)	7- 8
7.9	Displaying Various Types of GOT System Information (System Information)	7- 9
7.10	Monitoring the Circuits of the PC CPU Sequence Program (Circuit Monitor)	7-10
7.11	Specifying the PC CPU Clock Data (Clock Setting)	7-11
7.12	Displaying the Display Section Cleaning Screen (Screen Cleaning)	7-12
7.13	Checking Data Information Stored by the Alarm History Function	7-13

8. Off-line Functions	8- 1
------------------------------	-------------

8.1	Table of Off-line Functions	8- 1
-----	-----------------------------------	------

9. Installation	9- 1 to 9- 4
------------------------	---------------------

9.1	Precautions Regarding Handling	9- 1
9.2	Installation Environment	9- 3
9.3	Attachment Procedures	9- 3

10. Maintenance and Inspection	10- 1 to 10- 4
---------------------------------------	-----------------------

10.1	Daily Inspection	10- 1
10.2	Periodic Inspection	10- 1
10.3	Precautions during Maintenance and Inspection	10- 2
10.4	Replacing the LCD Backlights	10- 2

11. Error Codes and Error Messages	11- 1 to 11- 3
---	-----------------------

11.1	Interpreting the Display Contents	11- 1
11.2	Tables of Error Codes and Error Messages	11- 2

12. System Configurations When Making Bus Connections	12- 1 to 12-19
--	-----------------------

12.1	Useful Information When Making Bus Connections	12- 3
12.1.1	PC CPU handling of the GOT with bus connections	12- 3
12.1.2	Restrictions when using a direct PC CPU connection	12- 3
12.1.3	Restrictions on the number of GOTs connected to a PC CPU	12- 4
12.1.4	Supplying power to the PC CPU and the GOT	12- 4
12.1.5	Resetting the hardware with a bus connection	12- 5
12.1.6	Precautions when using the A7GT-BUS	12- 5
12.2	Switch Settings for a Bus Connection Module	12- 6
12.3	System Configuration When Connecting One GOT Module	12- 9
12.3.1	When setting GOT within the maximum expansion distance	12- 9
12.3.2	Case of installing GOT at locations beyond the maximum expansion distance	12-10
12.4	System Configuration When Connecting Two GOT Modules	12-11
12.4.1	When connecting to large-sized PC CPU	12-11
12.4.2	When connecting to small-sized PC CPU	12-12

12.5	System Configuration When Connecting Three GOT Modules	12-13
12.5.1	When connecting to large-sized PC CPU	12-13
12.5.2	When connecting to small-sized PC CPU	12-14
12.6	System Configuration during Bus Connection with A0J2HCPU	12-15
12.6.1	System configuration with connection of one GOT module	12-15
12.6.2	System configuration with connection of two GOT modules	12-17
12.7	Differences between A7GT-BUS/BUS2 and A7GT-BUSS/BUS2S	12-19

Appendix

Appendix- 1 to Appendix- 5

Appendix 1.	A870GOT External Dimensions Diagram	Appendix- 1
Appendix 2.	Depth Dimension When Loading Communications Module	Appendix- 2
Appendix 3.	A8GT-70PRF External Dimensions Diagram	Appendix- 4
Appendix 4.	A7GT-CNB External Dimensions Diagram	Appendix- 4
Appendix 5.	A8GT-70KBF External Dimensions Diagram	Appendix- 5

About the Manuals

The following product manuals are available. Please use this table as a reference to request the appropriate manual as necessary.

Related Manuals

Manual Name	Manual No. (Model Code)
<p>SW2NIW-A8GOTP Graphic Settings Software Package Operating Manual (Introductory Manual)</p> <p>This manual is designed for the first-time user of the A870GOT. It describes how to create monitor screens with the A8GOTP, how to send monitor data to the A870GOT, and what the various screen displays mean.</p> <p>(Included in the same package.)</p>	<p>IB-66679 (13J900)</p>
<p>SW2NIW-A8GOTP Graphic Settings Software Package Operating Manual (Startup Manual)</p> <p>This describes the configuration of the A8GOTP system, precautions regarding the configuration, and the specifications of the various functions, as well as the installation procedures, startup procedures, screen configurations, and basic operation procedures.</p> <p>(Included in the same package.)</p>	<p>IB-66680 (13J901)</p>
<p>SW2NIW-A8GOTP Graphic Settings Software Package Operating Manual (Monitor Screen Creation Manual)</p> <p>This describes procedures for creating monitor screens, monitor functions that can be used with the A870GOT, procedures for setting the monitor functions, precautions to be observed when creating monitor screens, and precautions to be observed when appropriating conventional GOT monitor data for use with the A870GOT.</p> <p>(Included in the same package.)</p>	<p>IB-66681 (13J902)</p>
<p>SW2NIW-A8GOTP Graphic Settings Software Package Operating Manual (Data Transmission/Debugging/Document Creation Manual)</p> <p>This manual describes the following items.</p> <ol style="list-style-type: none"> (1) Procedures for downloading project data to the A870GOT and uploading data from the A870GOT (2) Procedures for installing the operating system in the A870GOT (3) Procedures for using the A8GOTP as a virtual PC and for debugging the A870GOT (4) Procedures for outputting created monitor data as a completed document <p>(Included in the same package.)</p>	<p>IB-66682 (13J903)</p>
<p>A870/A850/A851GOT Graphic Operation Terminal Operating Manual (Expanded Functions Manual)</p> <p>This manual describes the operation procedures for using system monitor functions, monitor functions for special function modules, and the dedicated monitor screens used with the circuit monitor functions.</p> <p>(Included in the same package.)</p>	<p>IB-66683 (13J904)</p>
<p>A8GT-MCAM Memory Cassette with Built-in Circuit Monitoring Function User's Manual</p> <p>This manual explains how to install the circuit monitor cassette in the A870GOT.</p>	<p>IB66634 (13J831)</p>
<p>A8GT-RS4 RS-422 Serial Communication Module User's Manual (Hardware Manual)</p> <p>This manual describes the names and settings for the various parts of the interface module, and how to install it in the A870GOT.</p>	<p>IB-66635 (13J832)</p>

Manual Name	Manual No. (Model Code)
<p>A7GT-BUS Bus Connection Interface Module User's Manual (Hardware Manual) This describes the specifications of the bus connection module , the names of parts, and how to enter settings.</p>	<p>IB-66556 (13JE92)</p>
<p>A7GT-BUSS Bus Connection Interface Module User's Manual (Hardware Manual) This describes the specifications of the bus connection module, the names of parts, and how to enter settings. (Included in the A7GT-BUSS.)</p>	<p>IB-66760 (13JL07)</p>
<p>A7GT-BUS2S Multidrop Bus Connection Interface Module User's Manual (Hardware Manual) This describes the specifications of the multidrop bus connection module, the names of parts, and how to enter settings. (Included in the A7GT-BUS2S.)</p>	<p>IB-66761 (13JL08)</p>
<p>A8GT-70PRF Printer Interface Module User's Manual (Hardware Manual) This describes the specifications of the A8GT-70PRF printer interface module, and how to enter settings etc. (Included in the A8GT-70PRF.)</p>	<p>IB-66706 (13J867)</p>
<p>A8GT-70KBF Operation Panel Interface Module User's Manual (Hardware Manual) This describes the specifications, the name of parts, installation method, and external dimensions diagram when using the module. (Included in the A8GT-70KBF.)</p>	<p>IB-66769 (13JL17)</p>
<p>A8GT-RS4 Serial Communication Module User's Manual This describes the specifications, the name of parts, installation method, and external dimensions diagram when using the module. (Included in the A8GT-RS4.)</p>	<p>IB-66764 (13JL11)</p>
<p>A8GT-PW24 Power Supply Module User's Manual (Hardware Manual) This describes the specifications, the name of parts, installation method, and external dimensions diagram when using the module. (Included in the A8GT-PW24.)</p>	<p>IB-66707 (13J868)</p>
<p>A7GT-J71AP23/R23 Data Link Module User's Manual This manual contains the specifications for the MELSECNET (II) Optical Data Link Module/MELSECNET (II) Coaxial Data Link Module, as well as the names and settings for the various parts.</p>	<p>IB-66438 (13JE26)</p>
<p>A7GT-J71AT23B Data Link Module User's Manual This contains the specifications for the MELSECNET/B Data Link Module, as well as the names and settings for the various parts.</p>	<p>IB-66439 (13JA81)</p>
<p>A7GT-J71LP23/BR13 Network Module User's Manual This manual contains the specifications for the MELSECNET/10 Optical Loop Network Module/MELSECNET/10 Coaxial Bus Network Module, as well as the names and settings for the various parts.</p>	<p>IB-66558 (13JE94)</p>
<p>MELSECNET, MELSECNET/B Data Link System Reference Manual This manual contains an overview of the MELSECNET (II) and MELSECNET/B, as well as the specifications, names of parts, and the various settings.</p>	<p>IB-66350 (13JF70)</p>

Manual Name	Manual No. (Model Code)
<p>MELSECNET/10 Network System Reference Manual (For PC Networks) This manual contains an overview of the MELSECNET/10, along with the specifications, names of parts, and the settings.</p>	<p>IB-66440 (13JE33)</p>
<p>Calculator Link/ Multidrop Link Module User's Manual (Calculator Link Functions/Printer Functions Manual) This manual describes the module settings, wiring, programming, troubleshooting procedures, and other information concerning communication with peripheral equipment using the dedicated protocol, the no-protocol mode and the bi-directional mode for the calculator link module, as well as printer functions. This manual can be used with the following calculator link modules : A1SJ71UC24-R2, A1SJ71UC24-R4, A1SJ71UC24-PRF, AJ71UC24, A2CCPUC24, A2CCPUC24-PRF, and A1SCPUC24-R2</p>	<p>SH-3511 (13JE77)</p>
<p>AJ71UC24 Calculator Link/ Multidrop Link Module User's Manual (Hardware Manual) This manual explains the system configuration when using the module, the module specifications, and the names of parts and the settings, and contains diagrams of the external dimensions.</p>	<p>IB-66559 (13JE95)</p>
<p>A1SJ71UC24-R4 Calculator Link/ Multidrop Link Module User's Manual (Hardware Manual) This manual explains the system configuration when using the module , the module specifications, and the names of parts and the settings, and contains diagrams of the external dimensions.</p>	<p>IB-66582 (13J805)</p>

1. Overview

This manual describes the specifications, handling procedures, and utility functions for the A870GOT Graphic Operation Terminal (hereafter abbreviated as GOT).

1.1 Features

The GOT can be used as an electronic operation panel in which all functions carried out on conventional operation panels can be done on a monitor screen, including switch operations, lamp displays, data display, and message displays.

Other functions which can be done with the GOT are circuit monitoring of the PC CPU, monitoring and changing device data, and monitoring and changing the buffer memory of the special functions module.

1 Three types of display modules available, to match user specifications

There are three types of display modules available, a 2-color EL model, an 8-color STN liquid crystal color model, and 15-color TFT liquid crystal color model. The differences between these two models are shown below. The user can select whichever model best fits the specifications at hand.

Item	A8GT-70GOT-EW A8GT-70GOT-EB (EL)	A8GT-70GOT-SW A8GT-70GOT-SB (STN)	A8GT-70GOT-TW A8GT-70GOT-TB (TFT)
Display colors	2 colors (yellow/orange and black)	8 colors	15 colors
Resolution	640 × 400 dots	640 × 480 dots	
Display size	120 mm (4.7 inch) (vertical) × 192 mm (7.6 inch) (horizontal)	158 mm (6.2 inch) (vertical) × 211 mm (8.3 inch) (horizontal)	
No. of touch keys *1	1000 points (25 rows × 40 columns)	1200 points (30 rows × 40 columns)	
No. of keys usable on 1 screen	Base screens	256 points max.	
	Window screens	209 points max.	

*1. This is the number that can be specified at the minimum resolution (16 dots × 16 dots).

2 Use of free-location touch keys

Touch keys can be freely positioned at any location, in 1-dot units. In addition, the minimum module for the key size is the width of one full-width character (16 dots × 16 dots). This gives the user greater freedom in creating monitor screens.

3 GOT CPU contains a 32-bit RISC*1 chip

The GOT contains a 32-bit RISC chip, which is used in combination with a 32-bit local bus for high-speed processing. This significantly reduces the amount of time required to switch monitor screens, refresh data displays, and for touch keys to respond.

*1 RISC: Reduced Instruction Set Computer

4 Improved maintenance access and resistance to environmental factors

- The GOT is equipped with backlights that use a liquid crystal display and are designed so that they can be replaced by the user. (A replacement backlight is available as an option.) In addition, the GOT is configured of a main display module, a power supply module, and a communications module which connect to the PC CPU. This modular configuration makes maintenance much easier when required by any of the modules.

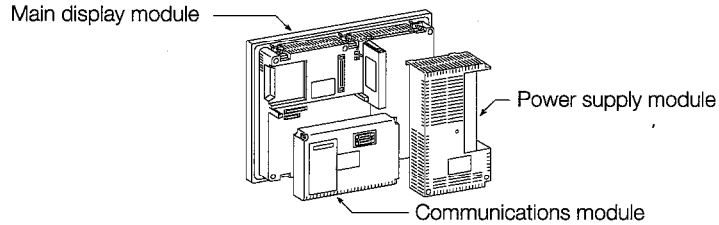

5 Accommodating diverse connection configurations such as bus connections and MELSECNET connections

In addition to bus connections which enable high-speed communications, the following are also possible. This provides the user with unlimited flexibility in system configuration.

The connection interface required depends on the configuration being used.

- Bus connection
- MELSECNET connection
- CPU direct connection
- Calculator link connection (RS-422 communication)
- MELSEC-FX series connection
- Omron PLC connection
- Microcomputer connection

- ① Bus connections (requires the A7GT-BUS/A7GT-BUS2/A7GT-BUSS, A7GT-BUS2S I/F module)

This configuration offers the fastest PC CPU response speed. If a large-sized PC CPU is connected, the GOT can be installed up to 36.6 m (120 feet) from the main base. With a smaller PC CPU, the GOT can be installed as far as 30m (98 feet) from the main base. In addition, up to three GOT modules can be connected to a single PC CPU. (There may be times when only two GOT modules can be connected, depending on the type of PC CPU.)

Required interface module A7GT-BUS, A7GT-BUS2/A7GT-BUSS, A7GT-BUS2S

Connecting to a large-sized PC CPU

- Connecting several GOT modules
- Connecting one GOT at more than 6.6 m (22 feet)

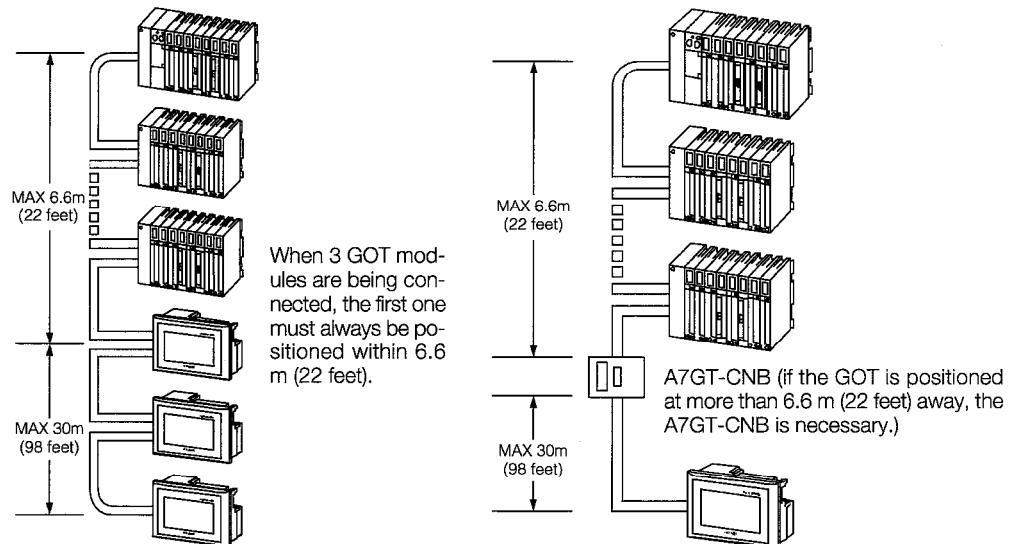

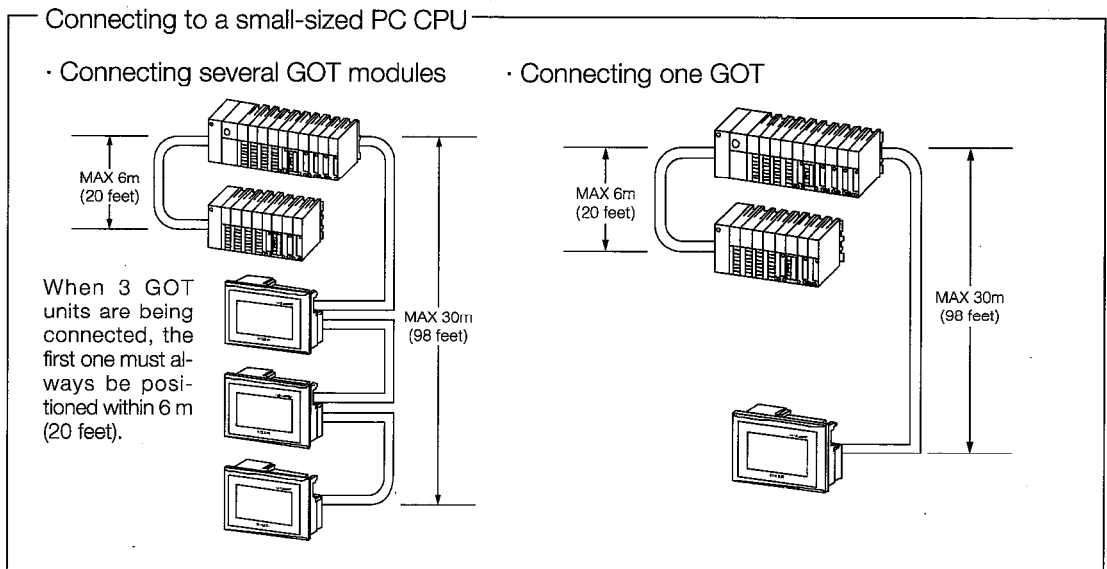

② MELSENET connections

This serves as a local station for a data link system, or an ordinary station for a network system, enabling several GOT modules to be connected to one system.

Required interface module A7GT-J71AP23, A7GT-J71AR23
 A7GT-J71AT23B data link module
 A7GT-J71LP23, A7GT-J71BR13 network module

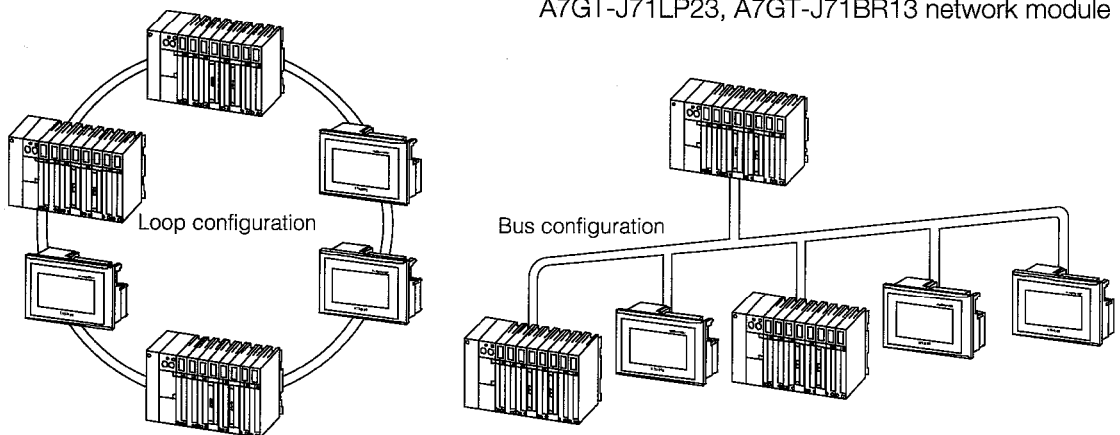

③ Calculator link connections

The GOT can be connected to a calculator link module in a 1-to-1 configuration, enabling connection of several GOT modules to one system.

Required interface module: A8GT-RS4 serial communication module

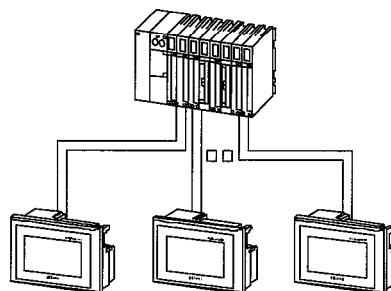

④ CPU direct connections

This is the most economical connection, requiring only an RS-422 cable.

Required interface module: A8GT-RS4 serial communication module

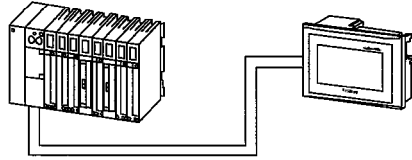

⑤ MELSEC-FX series connection

Connection with the MELSEC-FX series directly and monitoring can be implemented.

Required interface module.....A8GT-RS4 serial communication module.

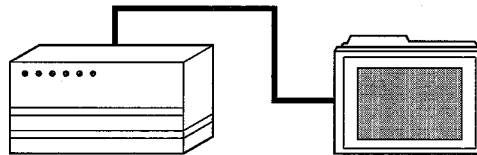

⑥ Connection of PLC made by Omron Corp.

Connection with PLC made by Omron Corp. (RS-422 communication) and monitoring can be implemented.

Required interface module.....A8GT-RS4 serial communication module.

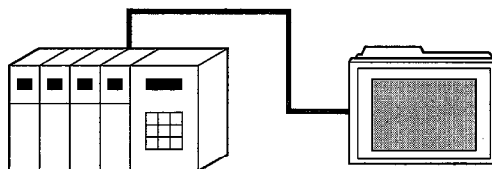

⑦ Microcomputer connection

Connection with microcomputer board or personal computer (RS-422 communication) and monitoring can be implemented.

While connected to microcomputer, the expansion function cannot be used.

Required interface module.....A8GT-RS4 serial communication module.

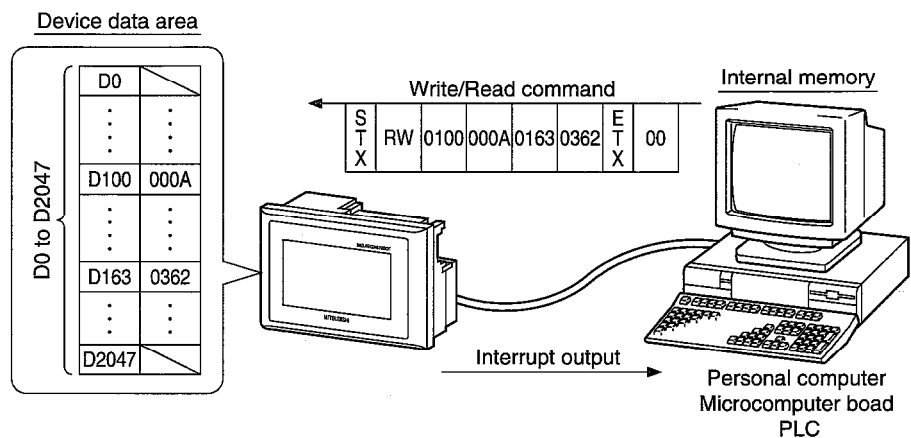

6 The following are supported as standard features: system monitor functions for monitoring and changing PC CPU devices, and special module monitor functions for monitoring and changing the buffer memory of a special functions module

- System monitor functions This enables monitoring of PC CPU devices and changes to set values and current values. (With the QnACPU, certain restrictions apply to monitoring.)

ENTRY MONITOR				MENU	FORM	SET	BATCH MONITOR					
NETWK No.[0]		STATION[FF]					NETWK No.[0]		STATION[FF]			
D	15	-2147483648	DW				D	10	32767	D	18	-500
D	10	-32767					D	11	0	D	19	3234
X	001	●					D	12	0	D	20	0
M	25	○					D	13	-1	D	21	0
Y	70	●					D	14	0	D	22	0
W	200		43				D	15	3	D	23	-32768
R	50	68378428	DW				D	16	0	D	24	0
D	0		3				D	17	0	D	25	0

TC MONITOR				MENU	FORM	SET	BM MONITOR						
NETWK No.[0]		STATION[FF]					NETWK No.[0]		STATION[FF]				
T	0	PV	0 SV	0	↑	○	▲	BM	1110	-32768	BM	1118	0
[Production line A]								BM	1111	64	BM	1119	0
T	1	PV	0 SV	0	↑	○	□	BM	1112	149	BM	1120	150
[Production line B]								BM	1113	-1111	BM	1121	131
T	2	PV	150 SV	150	■	●	□	BM	1114	126	BM	1122	-32768
[Production line C]								BM	1115	160	BM	1123	555
T	3	PV	0 SV	0	↑	○	▼	BM	1116	255	BM	1124	2368
[Production line D]								BM	1117	1200	BM	1125	11000

- Special module monitor functions This enables monitoring of and changes to the buffer memories on approximately 200 system screens.

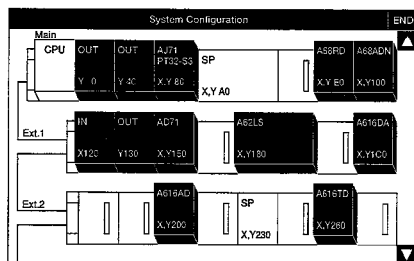

AD71 specified

SET/	DATA	MONIT	END
RESET	Chg.	MENU	
X	Y		
Posit. Start	Travel/Pulse	X Axis	X
Interpolation	Including Trav.		
Posit. Demand		Y Axis	Y
Zero Request	Speed Limit		
Zero Start	Acc./Dec. Time		
Zero Complete	Log./Spd.Limit		
Prod./Jog Start	Backlash Comp.		
Rev./Jog Start	Upper Limit		
Stop	Lower Limit		
Pos. Starbed	Error Damp.		
BUSY	Starting Bias		
N Code ON	Module/ScrMode		
MDT Error			
Best Start			
Error			

7 Circuit monitor functions for monitoring sequence programs available as an option

By installing a circuit monitor cassette in the GOT main module, circuit monitor functions can be used to monitor sequence programs. (Monitoring of the QnACPU is not possible.)

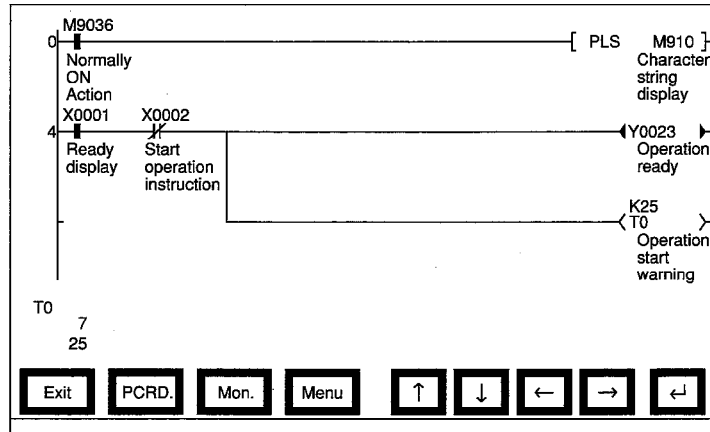

8 Screen debugging without connecting PC CPU

The graphics software supports a screen debugging function, so screens can be debugged simply by connecting the GOT and computer, without connecting the PC CPU.

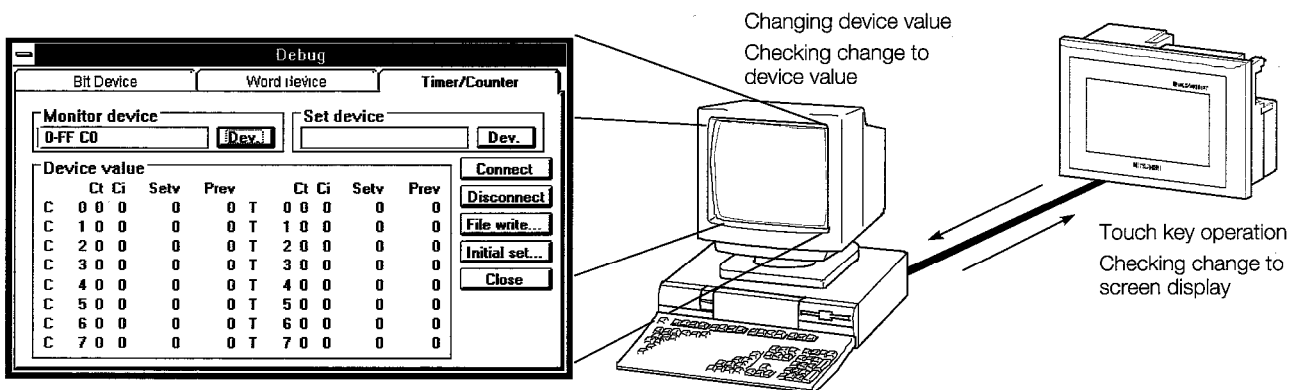

9 Worldwide access through multi-language capability

The Unicode*² system is used to enable approximately 26,000 characters to be used, making it possible to accommodate languages from all over the world, including Japanese, Korea, Chinese (Mandarin), English, Italian, and French.

*² Unicode = a standard international character code

10 Graphics software is easier to use than ever before

The graphics software runs on Windows 3.1, Windows 95*³, so it can be used in a variety of development environments. Both Japanese and English can be used on-screen.

Through Windows, operation is easier than ever before.

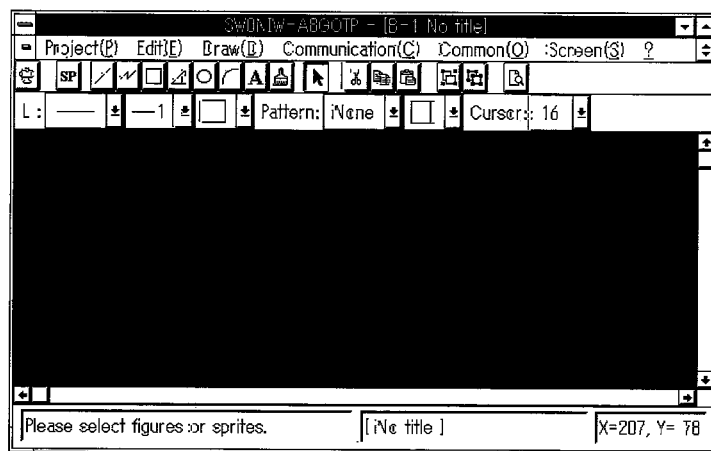

In addition, a panel kit library significantly reduces the amount of time required to create screens.

*³ Windows 3.1, Windows 95 is a registered trademark of Microsoft Corporation (U.S.).

1.2 Structure and Guide to the Use of This Manual

When the GOT is purchased, it comes with a user's manual. The graphics software also comes with five operating manuals. Manuals are categorized according to the purpose for which they are used. Please read the manual that corresponds to your particular objective in order to become familiar with the operations and functions of the software.

A870GOT User's Manual

- Install optional modules (communications module, power supply module) in the GOT.
- Connect the GOT and the PC CPU.
- Find out how to attach the GOT and its external dimensions.
- Select a model.

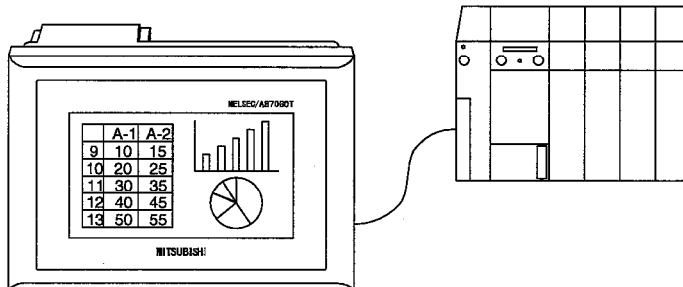
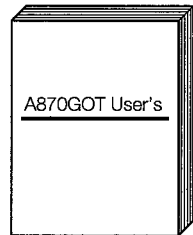

SW2NIW-A8GOTP Operating Manual

A870GOT Operating Manual

- Install the graphics software in the computer.
- Start up the graphics software.
- Learn fundamental information and basic operations for the graphics software.

SW2NIW-A8GOTP Operating

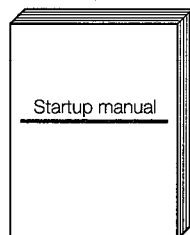

Personal computer

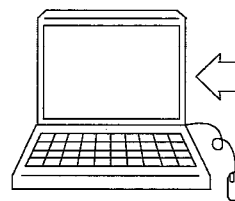

Graphics software

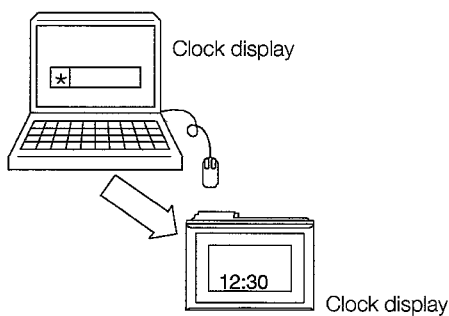

SW2NIW-A8GOTP Operating

- Create simple graphics, monitor using the GOT, and learn the flow of a series of operations.

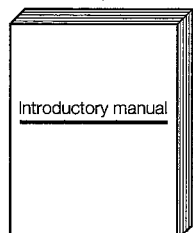

SW2NIW-A8GOTP
Operating

- Actually create screens for monitoring using the GOT.
- Drawing graphics
- Sprite settings
- Edit the data which has been created.

Monitor screen creation manual

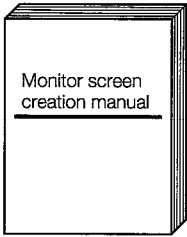
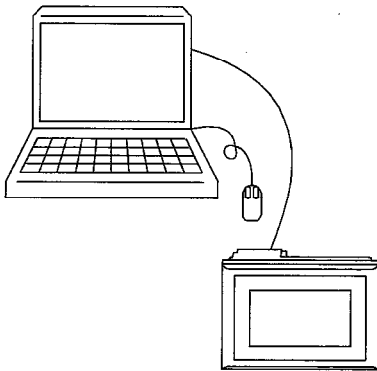
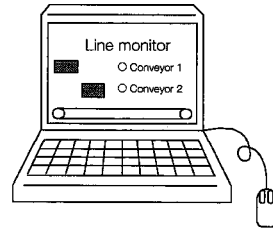
SW2NIW-A8GOTP
Operating

- Install the OS program and communications driver in the GOT.
- Download created graphics to the GOT.
- Debug graphics between the computer and GOT.
- Create data documents.

Data transmission
Debugging
Document creation
manual

A870/A85□GOT
Operating

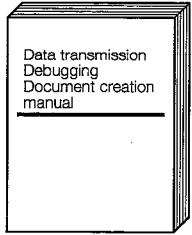
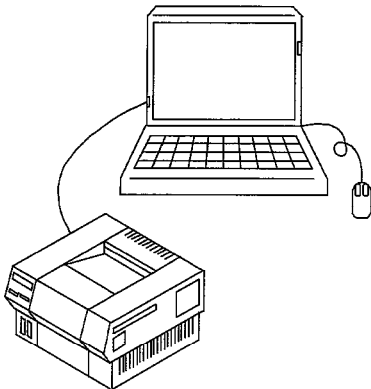
- Monitor circuits.
- Monitor the system.
- Monitor the special module.

Expanded functions manual

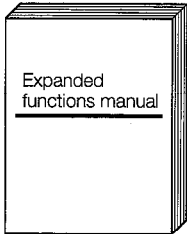

Circuit monitor

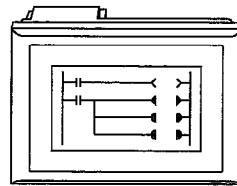

System monitor

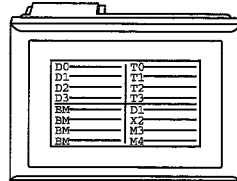

Special module monitor



1.3 Abbreviations and Symbols Used in This Manual

- (1) GOT This is the abbreviation for the A870GOT Graphic Operation Terminal. When the model name needs to be made explicit, however, "A870GOT" may be used.
- (2) OS This is the abbreviation for the GOT system software.
- (3) Internal memory This is the abbreviation for the memory (flash ROM) built into the GOT.
- (4) Memory cassette This refers to the A8GT-MCAM circuit monitor cassette.
- (5) Bus This refers to the A7GT-BUS connection interface module.
- (6) Bus 2 This refers to the A7GT-BUSS bus connection interface module.
- (7) BUSS This refers to the A7GT-BUSS bus connection interface module.
- (8) BUS2S This refers to the A7GT-BUS2S multidrop bus connection module.
- (9) Bus connection module This is a general term for the A7GT-BUS, A7GT-BUS2, A7GT-BUSS, or A7GT-BUS2S.
- (10) Calculator link module This refers to the AJ71UC24 calculator link module and the A1SJ71C24-R4 calculator link module.
- (11) Data link module This refers to the A7GT-J71AP23, A7GT-J71AR23, and A7GT-J71AT23B data link modules.
- (12) Network module This refers to the A7GT-J71LP23 and A7GT-J71BR13 network modules.
- (13) Serial communications module This refers to the A8GT-RS4 serial communications module.
- (14) Communications module This refers to any module used for communications, such as a bus connection module, a calculator link module, a data link module, a network module, or a serial communications module.
- (15) Power supply module This refers to the A8GT-PWEL or the A8GT-PWST power supply module.
- (16) Backlight This refers to the A8GT-70LTS or the A8GT-70LTT backlight.
- (17) Protective sheet This refers to the A8GT-70PSCE or A8GT-70PSCS transparent protective sheet, and to the A8GT-70PSNE or A8GT-70PSNS anti-reflection protective sheet.
- (18) Memory card This refers to a memory card which conforms to the JEIDA Ver. 4.0 standards.

- (19) Graphics software This refers to the SW1NIW-A8GOTP Graphic Operation Terminal software package.
- (20) Windows computer This is a personal computer which run Windows*1 Ver. 3.1.
- (21) Personal computer This refers to a module of peripheral equipment such as a Windows computer, on which the graphics software has been installed.
- (22) Peripheral equipment for GPP functions This is a general term for peripheral equipment which supports GPP functions, such as the A6GPP, A6PHP, A6HGP, A7PHP, LM7000, LM7500, or PC9801.
- (23) MNET (II) This is an abbreviation for the MELSECNET (II) data link system.
- (24) MNET/B This is an abbreviation for the MELSECNET/B data link system.
- (25) MNET/10 This is an abbreviation for the MELSECNET/10 network system.
- (26) CPU direct connection This refers to a system in which the GOT is connected to the PC CPU interface using an RS-422 cable.
- (27) Bus connection This refers to a system in which the GOT is connected to the main base or expansion base using an expansion cable.
- (28) Long-distance bus connection cable General term referring to long-distance connection cables such as the A7GT-C100EXS, A7GT-C200EXS, A7GT-C300EXS, A7GT-C100EXSS, A7GT-C200EXSS, and A7GT-C300EXSS.
- (29) Long-distance GOT connection cable General term referring to long-distance cables used between GOT, such as the A7GT-C100B, A7GT-C200B, A7GT-C300B, A8GT-C100BS, A8GT-C200BS, and A8GT-C300BS.
- (30) Bus connector conversion box Abbreviation referring to the A7GT-CNB bus connector conversion box.
- (31) Calculator link connection This refers to a system in which the GOT is connected to the AJ71UC24, A1SJ71C24-R4, AJ71C24-S8, or AJ71QC24-R4.
- (32) MELSECNET connection This refers to a system in which the GOT is connected to the MELSECNET (II), the MELSECNET/B, or the MELSECNET/10.
- (33) MELSEC-FX series connection Abbreviation of system in which GOT is connected to MELSEC-FX series

- (34) Connection of PLC by Omron Corp Abbreviation of system in which GOT is connected to PLC by Omron Corp.
- (35) Microcomputer connection..... Abbreviation of system in which GOT is connected to microcomputer board or personal computer
- (36) Project data This refers to all of the data created using the graphics software, such as screen data.

*1 Windows is a registered trademark of Microsoft Corporation.

1.4 Parts Supplied with This Product

When your GOT is purchased, the system is packaged so as to meet your application needs. After unpacking the GOT, please check to make sure the following components have been included.

1 When purchasing the A870GOT-EWS/A870GOT-SWS/A870GOT-TWS

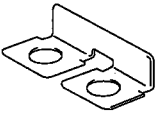
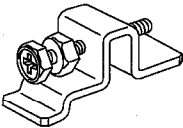
Product Name	Quantity
GOT main module	1
Power supply module *1	1
Power terminal short connection piece 	1
Installation fastener 	6

*1 The power supply module is installed in the GOT main module.

2 When purchasing the A8GT-70GOT-EB/A8GT-70GOT-SB/A8GT-70GOT-TB

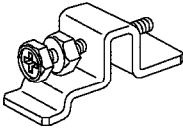
Product Name	Quantity
GOT main module	1
Installation fastener 	6

3 Install the fastener.

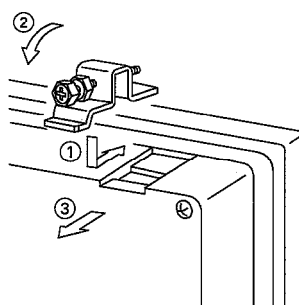

Slip in the fastener in the direction shown in ① and then fasten the fastener in the order of ② the ③.

4 The sheet affixed to the GOT display module

When the GOT is shipped, a protective sheet is affixed over the display module. This is a temporary sheet and is not the protective sheet which prevents the display module from being scratched or damaged during actual use.

After the GOT has been attached to its base, peel off this temporary sheet and cover the display module with the protective sheet or the anti-reflection protective sheet, both of which are sold separately.

1.5 Precautions When Installing the ROM_BIOS/OS

Notes about executing the ROM_BIOS/OS installation are described in the following.

- (1) Before installing the ROM_BIOS/OS, confirm that the connectors of the communication cable are securely connected to the GOT and the personal computer.

If the ROM_BIOS/OS installation is executed when the connectors are not connected securely, the GOT might stop operating after installation.

- (2) Note that the ROM_BIOS/OS installation cannot be interrupted once it is started.

The GOT might stop running if the power of the GOT or personal computer is turned off, or the communication cable is disconnected in order to interrupt in the middle of the installation.

- (3) Do not turn off the power of the GOT or personal computer, and do not disconnect the communication cable during the ROM_BIOS/OS installation.

The GOT might stop running if the power of the GOT or personal computer is turned off, or the communication cable is disconnected during the ROM_BIOS/OS installation.

- (4) If one of the operations described above was done by mistake, or if the GOT does not work after the ROM_BIOS/OS installation, follow the steps shown in the following to reinstall the ROM_BIOS/OS.

- ① Turn off the power of the GOT.
- ② If a communication module is installed, disconnect the communication module.
- ③ Turn on the power of the GOT while pressing the two locations on the GOT display simultaneously as shown in ■ of the following diagram:

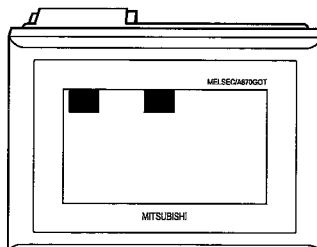

- ④ A message, "Reinstall ROM_BIOS/OS", will appear on the GOT display.
- ⑤ Reinstall the ROM_BIOS/OS. Refer to Section 3.1 of "SW2NIW-A8GOTP Graphic Settings Software Package Operating Manual" (Data Transmission/Debugging/Document Creation Manual).

2. System Configuration

2.1 Equipment Required for A870GOT

The equipment required for A870GOT is shown below.

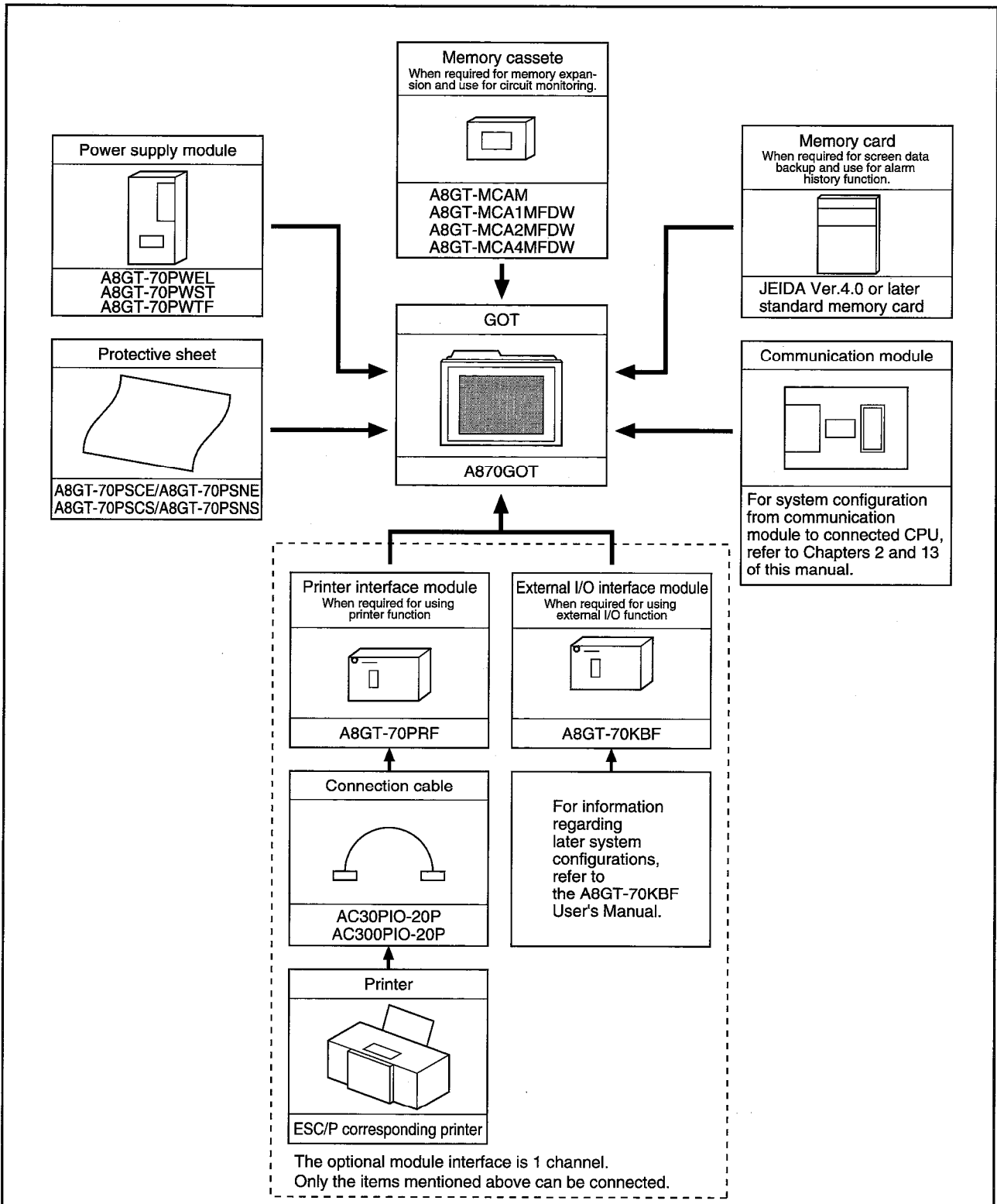

2.2 System Configuration When Creating Monitor Screens

This shows the system configuration when using the graphics software to create monitor screens.

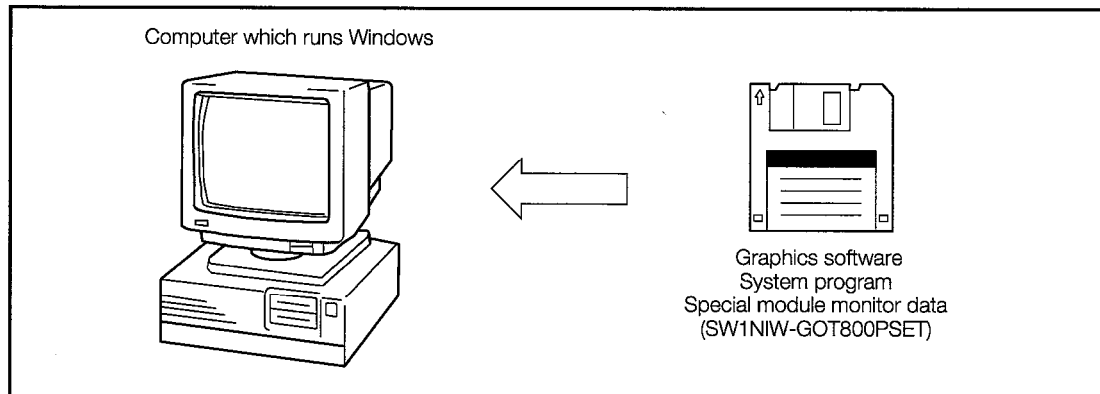

- Main module : Personal computer which runs Microsoft Windows Ver. 3.1/95
- Main memory : At least 4 MB is required (8 MB or more is strongly recommended)
- Hard disk : At least 10 MB of space must be available when the program is installed
- CRT : Must be able to connect to main module and be used with Microsoft Windows
- Mouse : Any mouse which can be used with a Windows computer

- Windows 3.1, Windows 95 is a trademark of Microsoft Corporation.

2.3 System Configuration Used for Data Transmission, Debugging, and Document Creation

2.3.1 System configuration

This shows the system configuration used for transmitting data, debugging, and creating documents.

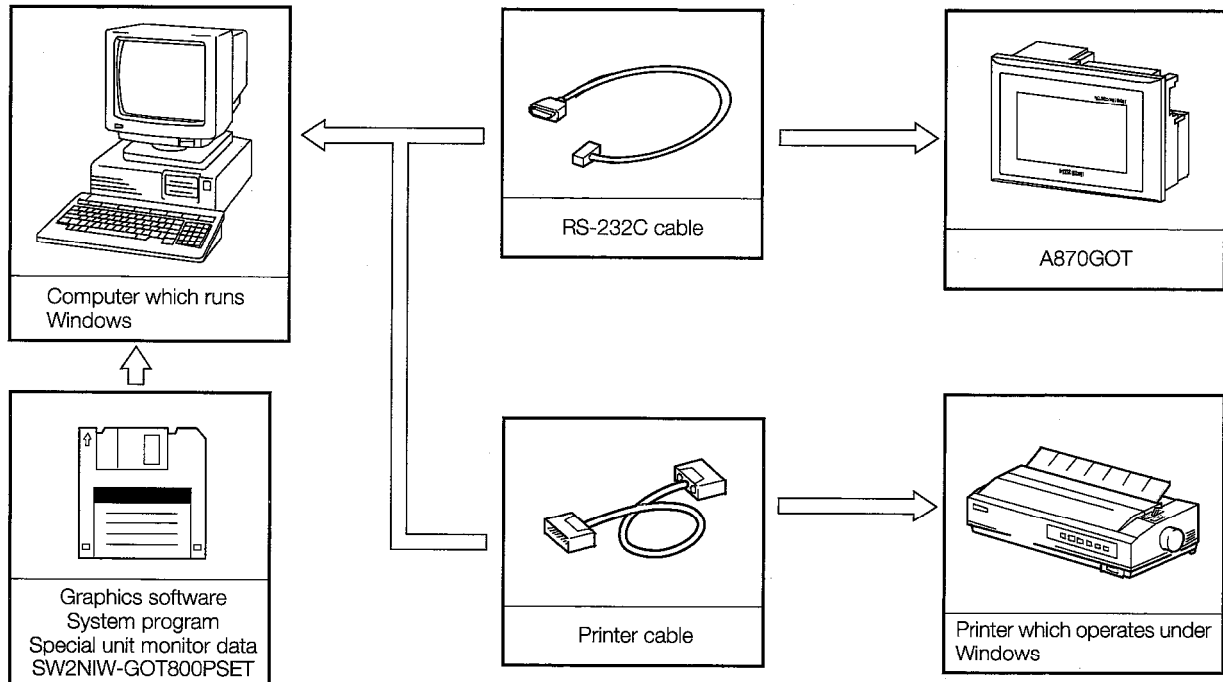

2.3.2 RS-232C cables used for data transmission

The cable shown in the internal connections drawing below, or a cable with the model name noted below, is required.

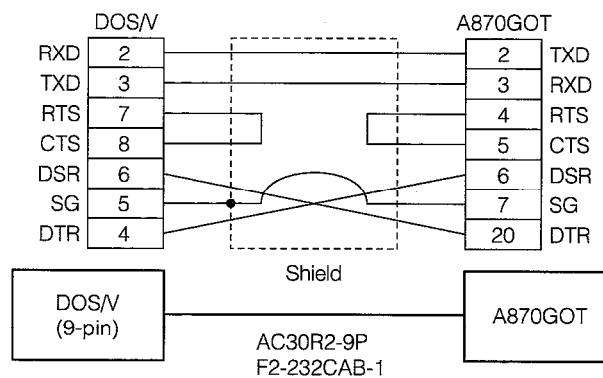

Maker	Model Name
Mitsubishi Electric	AC30R2-9P
	F2-232CAB-1 (introductory product)

2.4 System Configuration When Monitoring Through CPU Direct Connection

This shows the system configuration used when the GOT is connected to the PC CPU using an RS-422 cable.

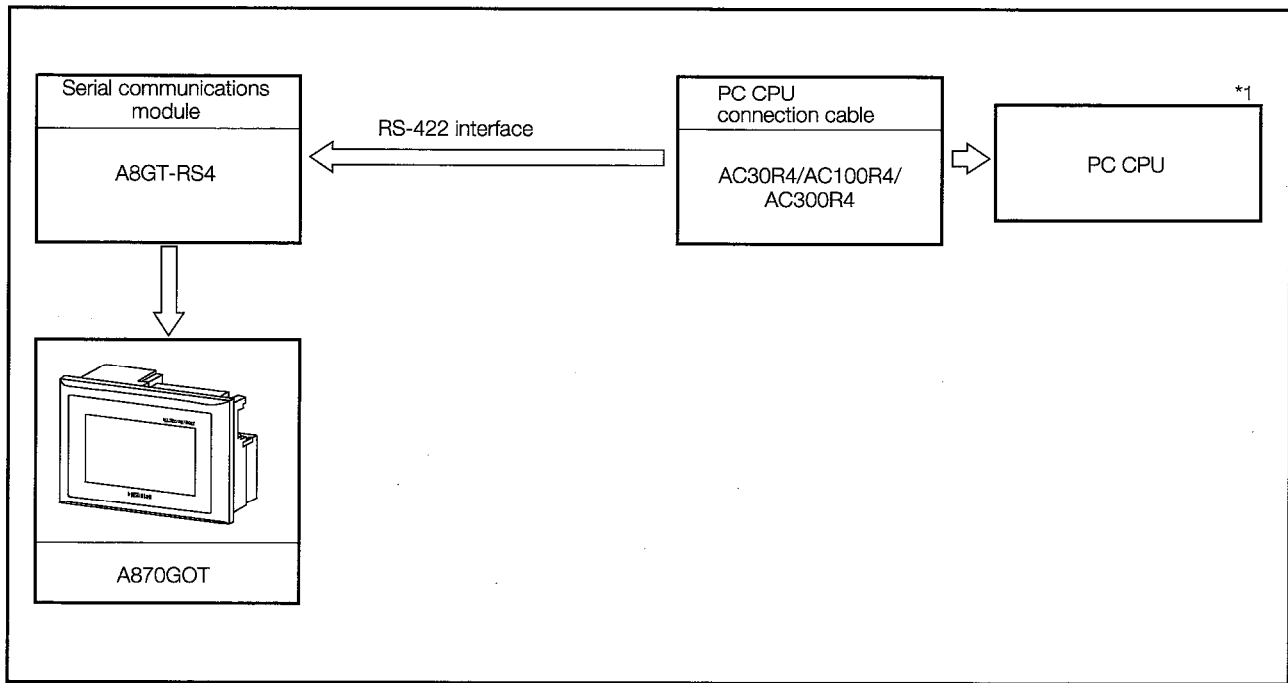

*1. The FX-2PIF dual-port interface module cannot be used with this configuration.

2.5 System Configuration and Precautions When Monitoring Through a Bus Connection

For information on the system configuration and the precautions when monitoring through a bus connection, please refer to Chapter 13.

2.6 System Configuration and Precautions When Monitoring Through a Calculator Link Connection (RS-422 Communication)

2.6.1 System configuration

When the GOT is connected to a calculator link module and a serial communications module using a calculator link module connection cable, the following system configuration is used.

- When connecting the calculator link module, a peripheral module designed for GPP functions can be connected to the RS-422 connector of the PC CPU and debugging of sequence programs carried out while monitoring the GOT.
- When connecting the calculator link module, the following are not possible: changes to the V or Z data in CPU device tests in the circuit monitor functions and system monitor functions; monitoring of or changes to the set value during T/C monitoring, monitoring of the I/O module, and monitoring of or changes to the special function module data using special screens.

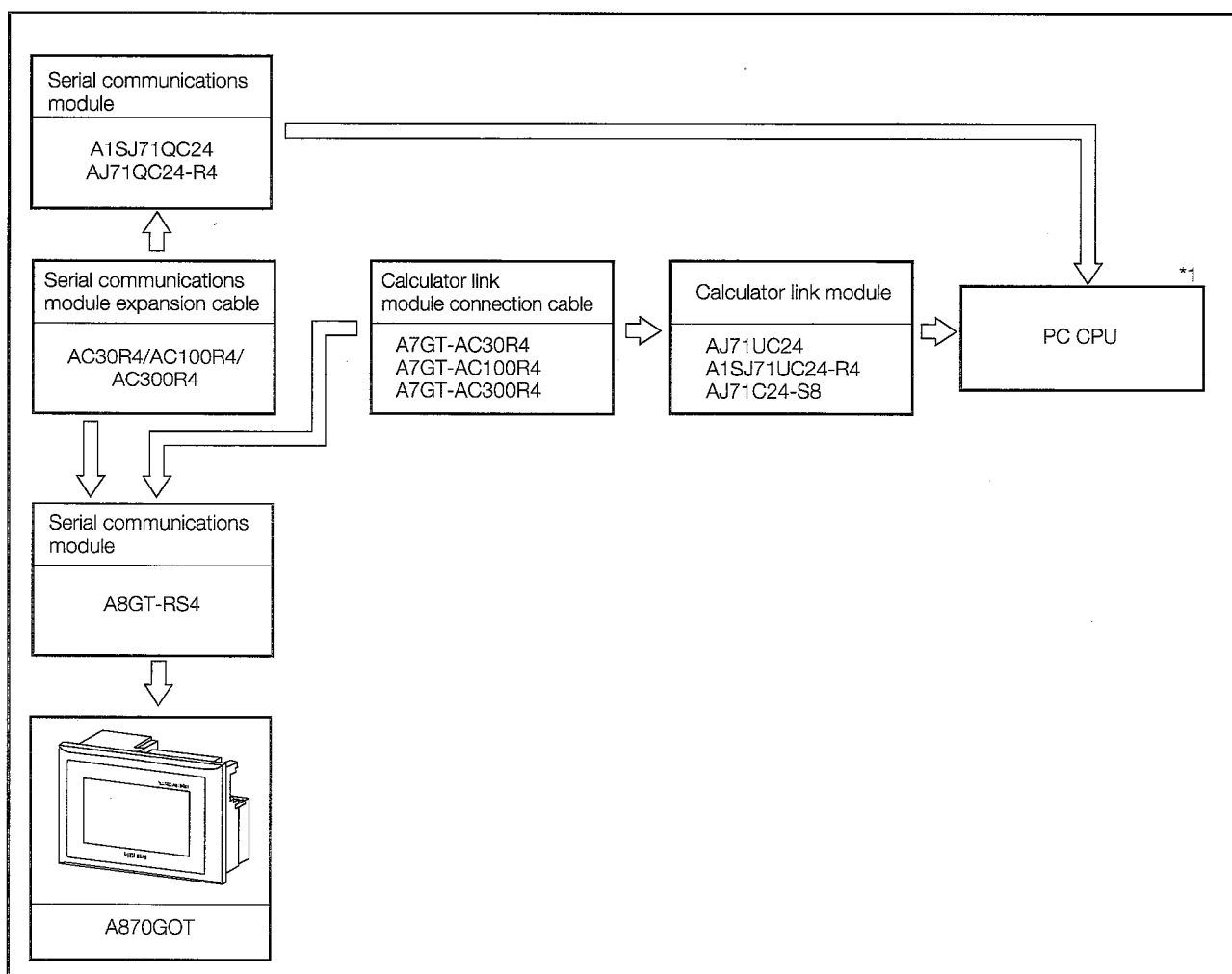

*1. For information on the system configuration on the calculator link module side, please refer to the user's manual for the calculator link module being used.

2.6.2 Precautions regarding the system configuration

- (1) The only calculator link modules or serial communication modules which can be connected and monitored are those listed below.
 - AJ71UC24
 - A1SJ71UC24-R4
 - AJ71C24-S8 (if the CPU to which the connection is being made is A□U, the device range which can be monitored is the A□A range)
 - AJ71QC24-R4
 - A1SJ71QC24
- (2) The GOT can only be connected to one calculator link module/serial communications module, in a 1-to-1 configuration.
The GOT cannot be connected to a calculator link module/serial communications module in an n-to-1 configuration.

• Example of connecting a GOT and calculator link module

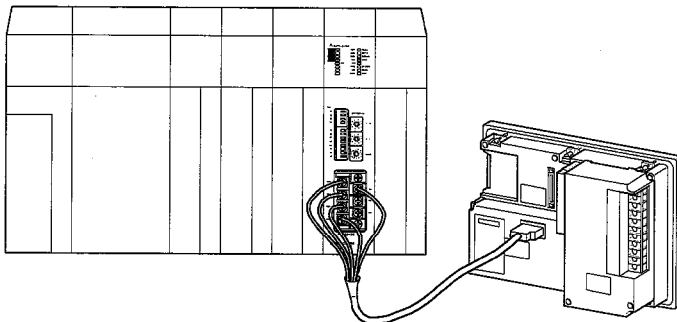

(A7GT-AC30R4/AC100R4/AC300R4)

• Example of connecting a GOT and serial communications module

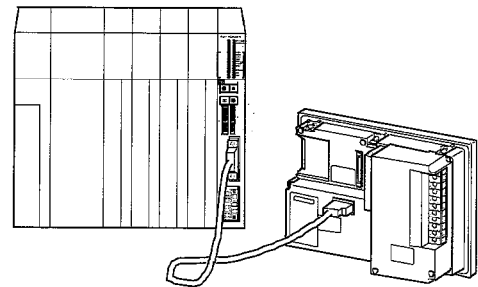

(AC30R4/AC100R4/AC300R4)

- (3) The table below shows the connectors, crimping terminals, and cables used when connecting the GOT and calculator link module with the following cables: A7GT-AC30R4, A7GT-AC100R4, A7GT-AC300R4.

(a) Connection diagram

Calculator link module side Signal	Cable connection and signal direction	G controller module side		Notes
		Pin no.	Signal name	
SDA		8	RDA	Receive Data
SDB		14	RDB	Receive Data
RDA		10	SDA	Send Data
RDB		16	SDB	Send Data
		11	RSA	Request to Send
		17	RSB	Request to Send
		9	CSA	Send Enabled
		15	CSB	Send Enabled
		5		
SG		12	SG	Signal ground
	6	SG (shield)		

(b) Connectors, crimping terminals, cables

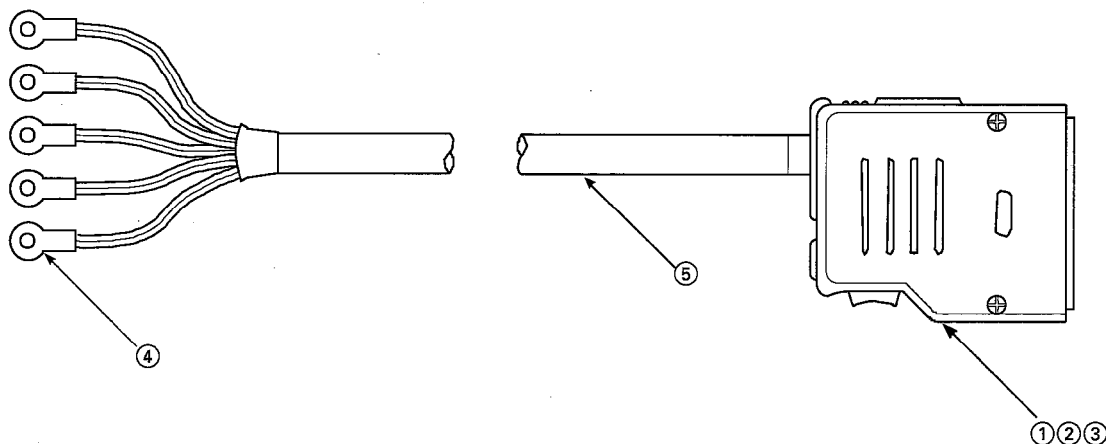

No.	Name	Model	Maker
①	Connector cover	P1620A-CA (20)	Hirose
②	Housing	SC-1620	Hirose
③	Contact	SC-1600-11	Hirose
④	Round crimping terminal	V1.25-M4	Nippon Crimping Terminal (recommended)
⑤	20-strand shielded cable	RF VV -SB-24 x 20	Toyokuni Power Cables (recommended)

(c) If you are creating your own cable to connect GOT and the calculator link module, please observe the following precautions.

- ① The cable length should be within 200 m (655.74 feet).
 - ② If ④ and ⑤ above are used to make the cable, the power cable can sometimes be disconnected if the connection is made with only one power cable. Two power cables should be used to make the connection.
- (4) When connecting GOT and calculator link module, it is not necessary to connect a final resistor on the calculator link module side.
- (5) The GOT cannot be monitored by connecting it to an AJ71UC24 or AJ71QC24-R4 which has been installed in an MNET/10 remote I/O station.

2.6.3 Hardware settings for the calculator link module

If monitoring is being done with the GOT connected to a calculator link module, the hardware settings for the calculator link module (mode setting switch and transmission specification switches) should be set as shown below.

Transmission specifications consist of the following: ① transmission speed: 19,200 bps, ② data bits: 8 bits, ③ parity bit: yes (odd), ④ stop bit: 1 bit, ⑤ sum check: yes.

1 When connected to the AJ71UC24

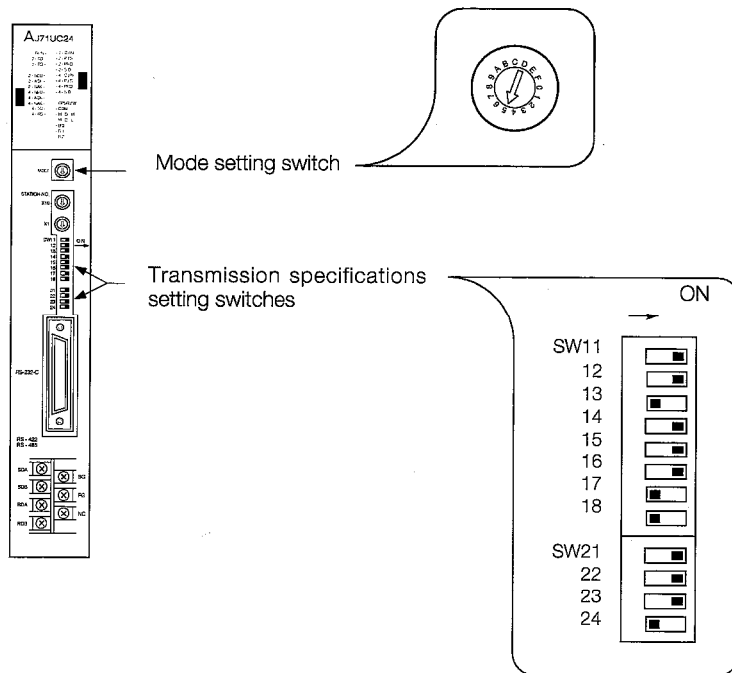

2 When connected to the A1SJ71C24-R4

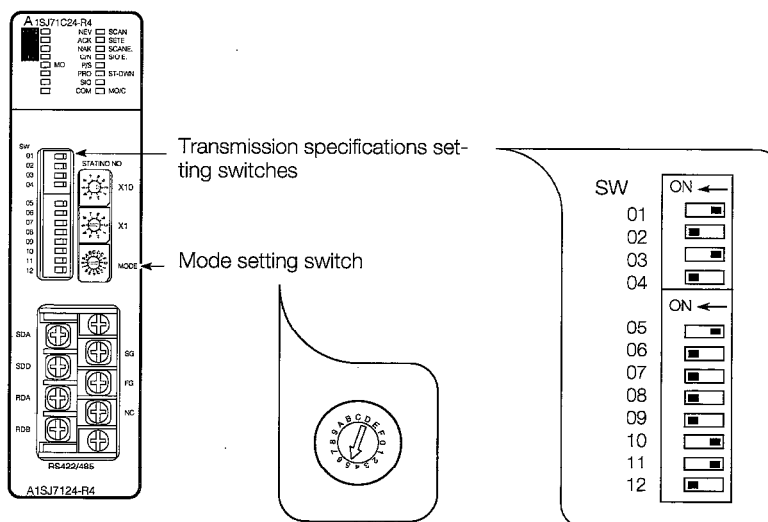

3 When connected to the AJ71C24-S8

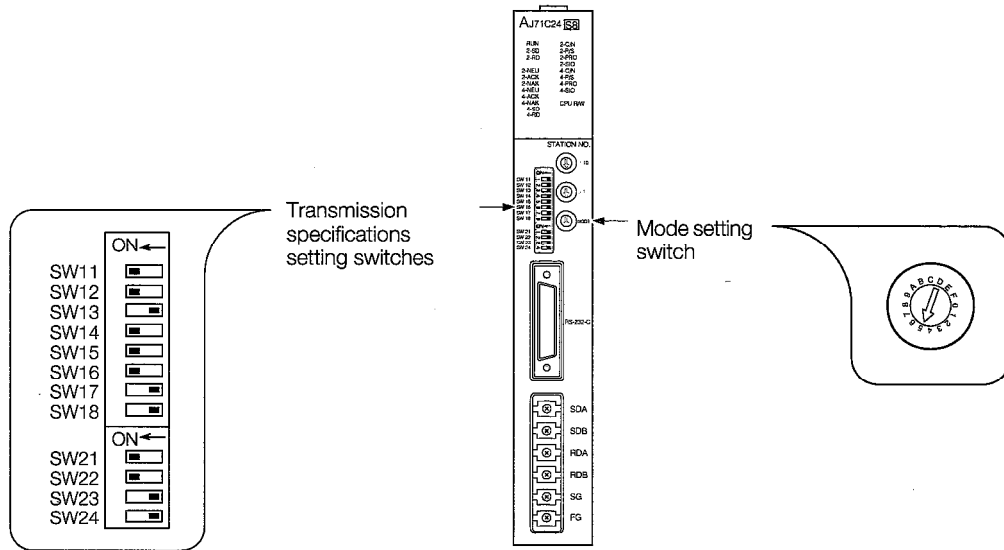

2.6.4 Hardware settings for the serial communications module

When the GOT is connected to a serial communications module for monitoring, the hardware settings for the serial communications module (mode setting switch and transmission switches) should be set as shown below.

Transmission specifications consist of the following: ① data bits: 8 bits, ② parity bit: yes (odd), ③ stop bit: 1 bit, ④ checksum: yes, ⑤ transmission speed: 19,200 bps.

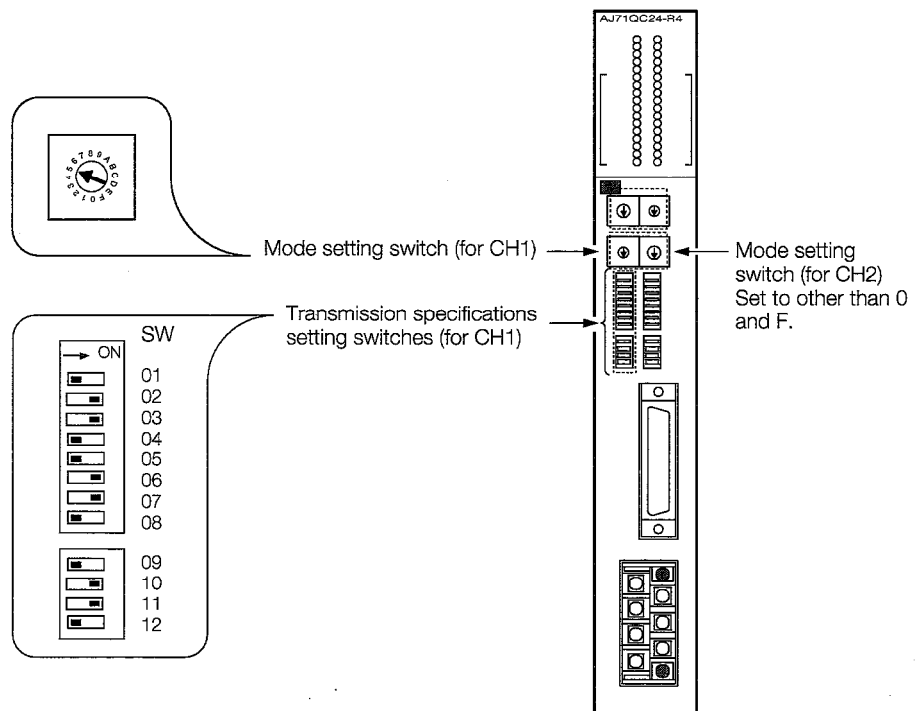

2.7 System Configuration When Monitoring Through a MELSECNET Connection (Connected to a Data Link System)

When the GOT is incorporated into a data link system, the system configuration is as shown below. The number of GOTs that can be connected is limited only by the number of stations that can be connected to the various data link systems.

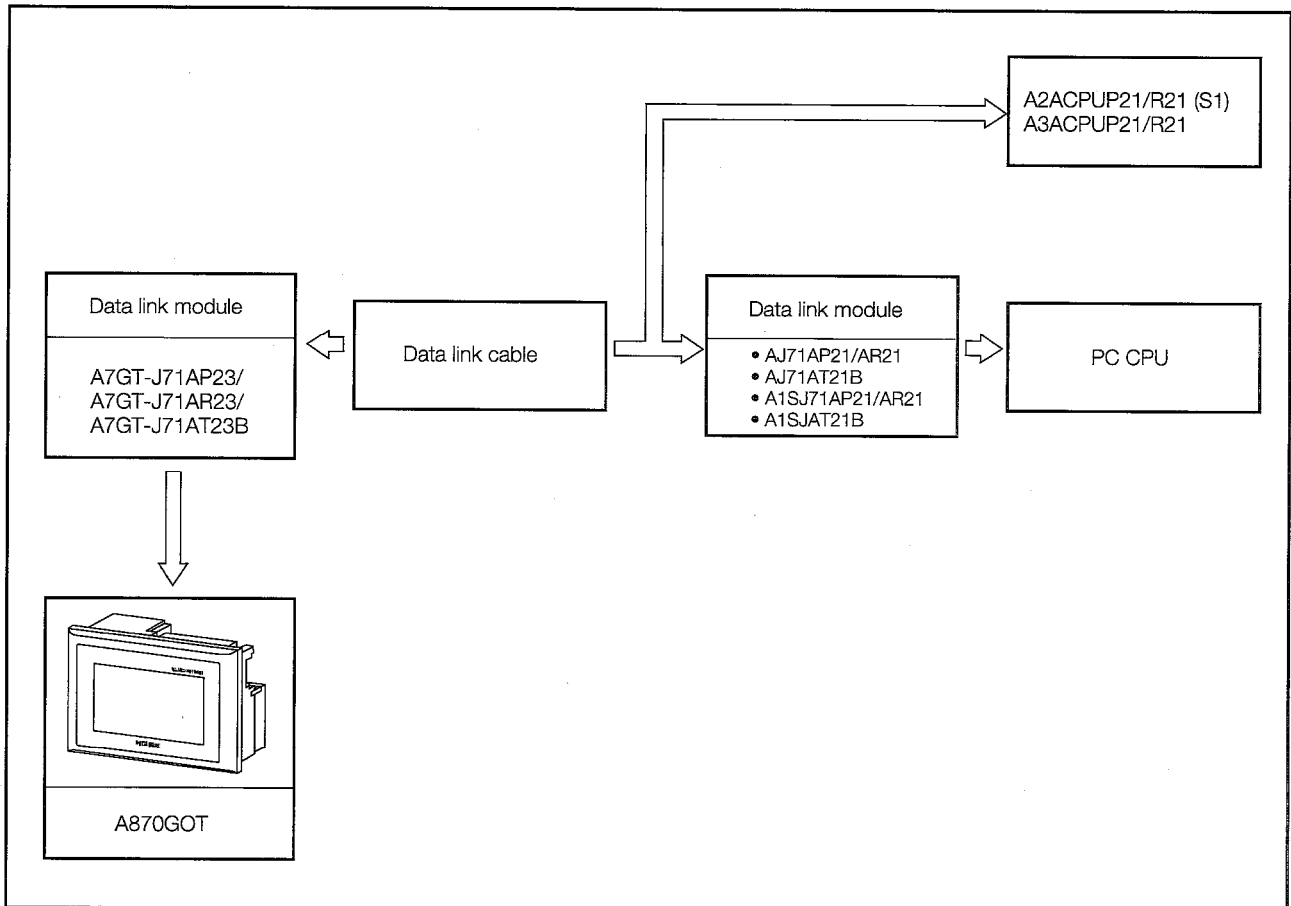

* For information on installing the data link module and entering switch settings, please refer to Section 5.4.3.

2.8 System Configuration When Monitoring Through a MELSECNET Connection (Connected to a Network System)

When the GOT is incorporated into a network system, the system configuration is as shown below. The number of GOTs that can be connected is limited only by the number of stations that can be connected to the various network systems.

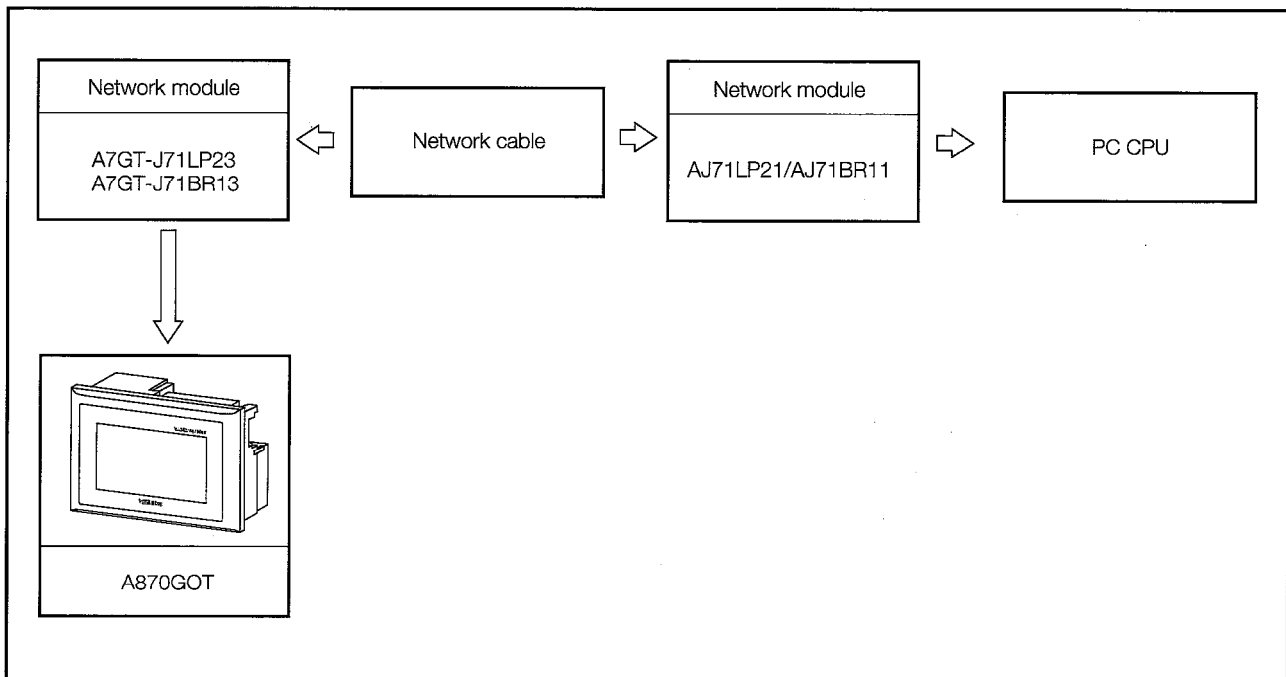

* For information on installing the network module and entering switch settings, please refer to Section 5.4.4.

2.9 System Configuration When Connecting to the MELSEC-FX Series

2.9.1 When connected to the FX0, FX0N, FX0s, and FX2N series

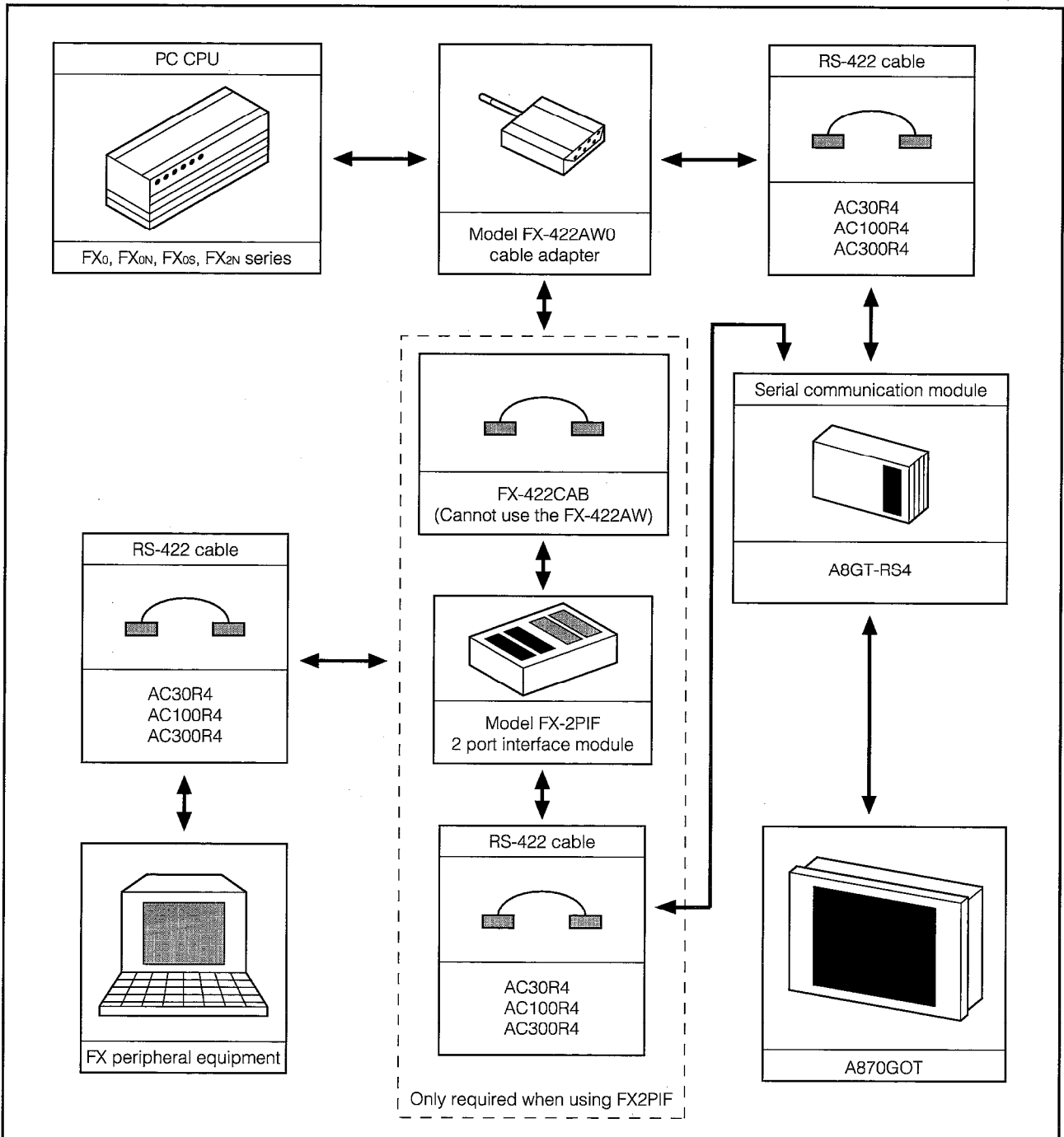

2.9.2 When connected to the FX1 and FX2, FX2c series

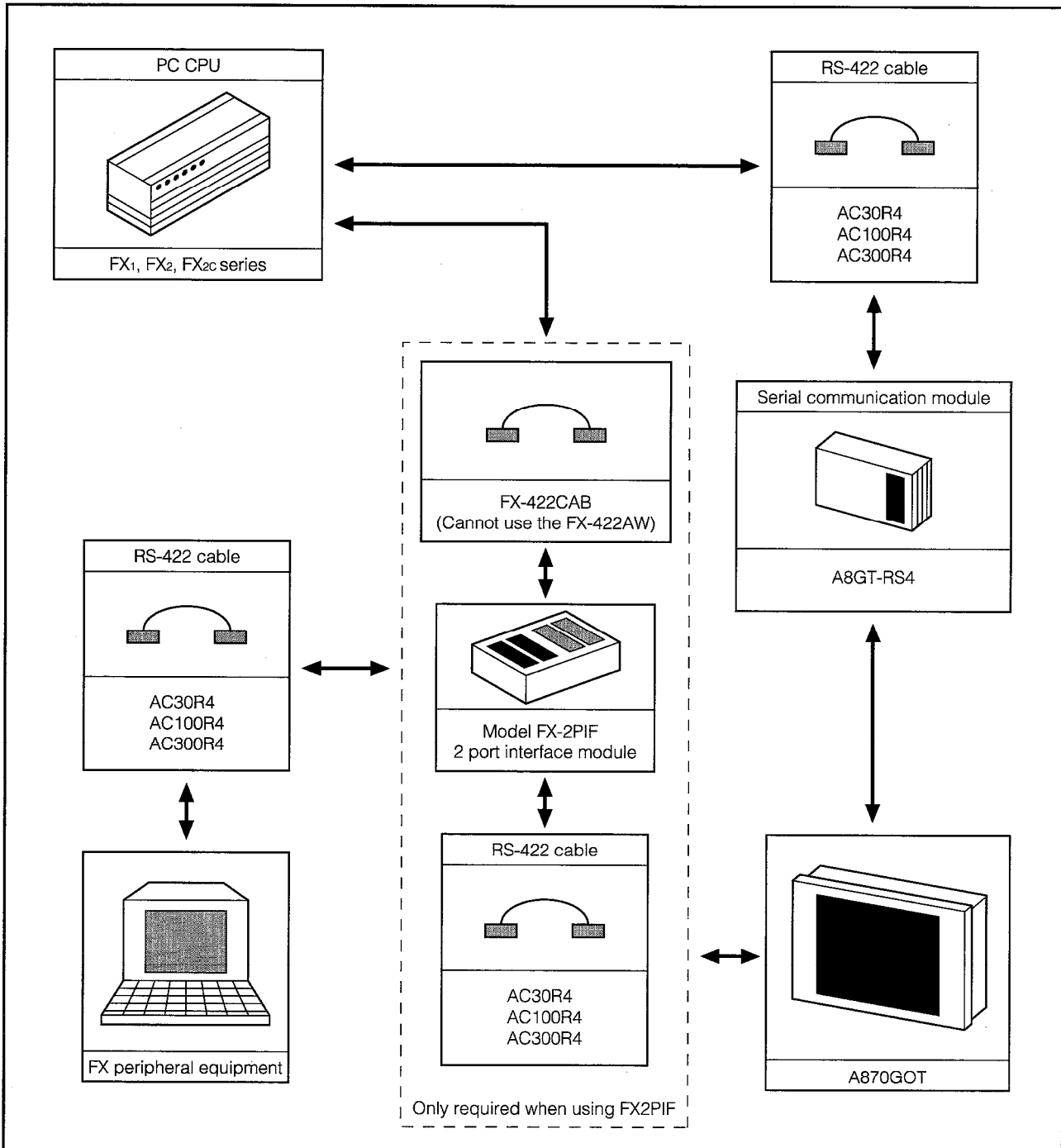

2.9.3 System configuration precaution items

- (1) For information regarding the devices and access ranges that can be monitored, refer to the SW2NIW-A8GOTP Operating Manual (Monitor Screen Creation Manual).
- (2) For details regarding connecting the CPU, refer to the products instruction manual.

2.10 System Configuration When Connecting to the Omron PLC

2.10.1 System configuration when connected to the C200H and C200HS

1 System configuration

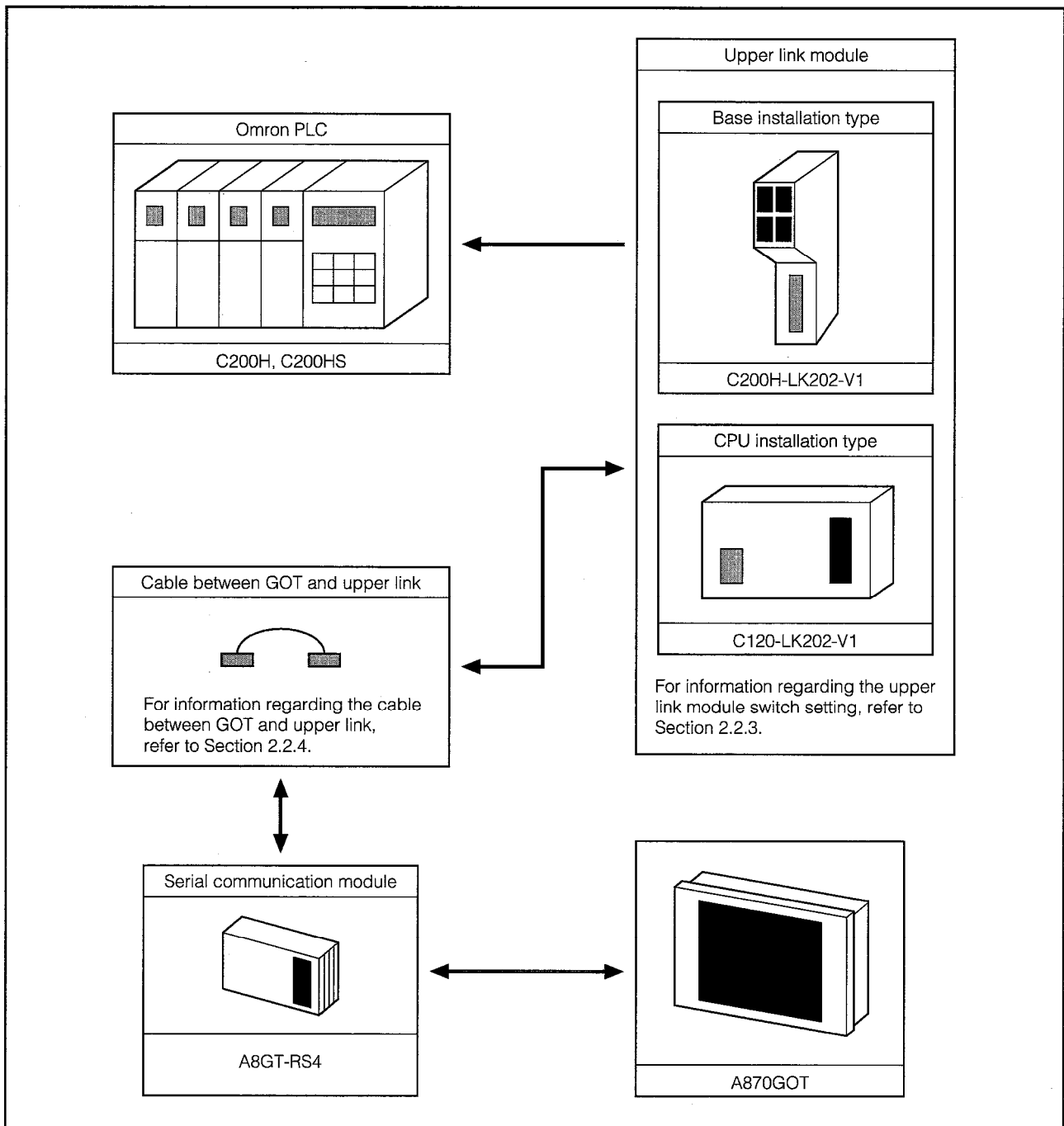

2 System configuration precaution items

- (a) The only upper link modules that can conduct monitoring while connected to the GOT are the C200H-LK202-V1 and the C120-LK202-V1. Other upper link modules cannot be connected, so be aware of this.
- (b) Monitoring cannot be conducted by directly connecting the PLC to the GOT.
- (c) For information regarding the devices and access ranges that can be monitored, refer to SW2NIW-A8GOTP Operating Manual (Monitor Screen Creation Manual).
- (d) For details regarding the connected upper link modules and connection destination PLC, refer to the products instruction manual.

3 Upper link module switch setting

Make the following switch settings in the upper link module.

- (a) C200H-LK202-V1 switch setting

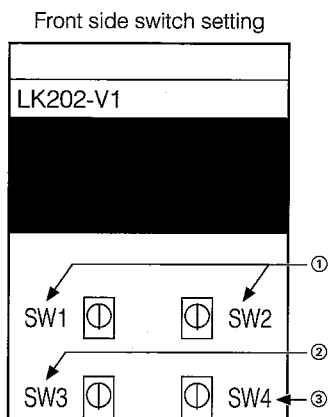

- ① SW1 and SW2 setting (Station No. setting)
Set SW1:0, and SW2:0.
(Set the station No. to 00.)

- ② SW3 setting (Transmission speed setting)
Set SW3:6
(Sets to 19.2 KBPS)

- ③ SW4 setting (Command level, parity, transmission code setting)
Set to SW4:2.
(Parity: Even, transmission code: ASCII 7 bits, 2 stop bits)

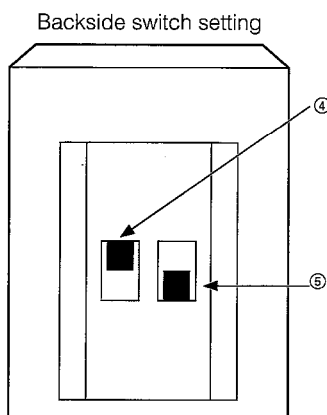

- ④ Set the end terminal resistance connection yes/no setting switch
Set to ON (Yes).

- ⑤ 1 procedure/N procedure setting switch setting
Set to OFF (N-steps).

(b) C120-LK202-V1 switch setting

Set the setting DIP switches (SW1, SW2, SW3) on the back side of the main module as follows.

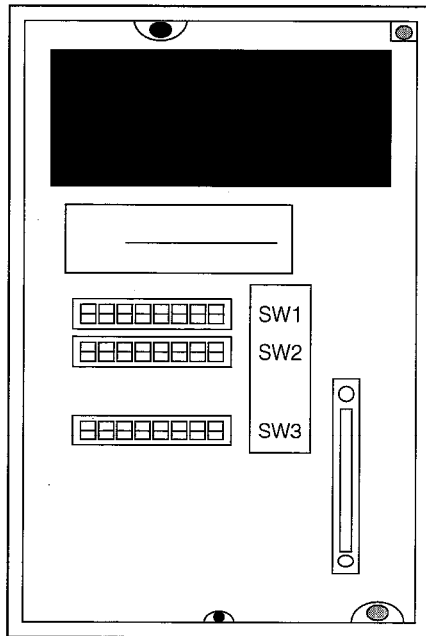

SW1 setting

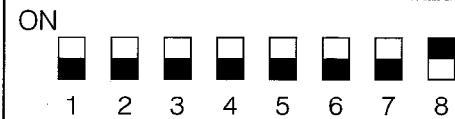

- ① Sets the station No. (SW1-1 to 5)
Set all to the OFF side (0 station).

- ② Start/stop setting (SW1-8)
Set to the ON side (Start).

Setting SW1-6, 7 is not required.

SW2 setting

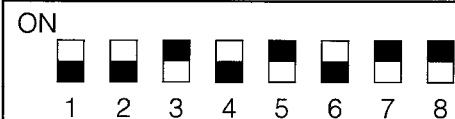

- ① Transmission speed setting (SW2-1 to 4)
Set to
SW2-1: OFF side, SW2-2: OFF side
SW2-3: ON side, SW2-4: OFF side.
(Set 19.2 KBPS.)
- ② 1:1 steps/1:N steps setting (SW2-6)
Set to OFF side (1:N steps).
- ③ Level setting (SW2-7, 8)
Set to
SW2-7: ON side, SW2-8: ON side.
(Set to make level 1, 2, and 3 valid.)
Setting SW2-5 is unnecessary.

SW3 setting

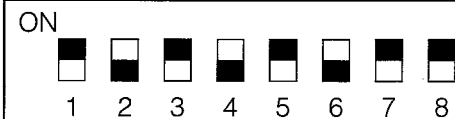

- ① Terminal resistor turn on setting (SW3-1 to 6)
Set to
SW3-1: ON side, SW3-2: OFF side
SW3-3: ON side, SW3-4: OFF side
SW3-5: ON side, SW3-6: OFF side.
(Set the terminal resistor)

Setting SW3-7, 8 is unnecessary.

4 Cable between the GOT and upper link module

The connection diagram and connector that connects the cable between the GOT and upper link module are shown below.

(a) Connection diagram

Upper link module side		Cable connection and Signal direction	GOT side		Remarks
Signal	Pin No.		Pin No.	Signal name	
SDA	5		8	RDA	Reception data
SDB	9		14	RDB	Reception data
RDA	1		10	SDA	Transmission data
RDB	6		16	SDB	Transmission data
			11	RSA	Transmission request
			17	RSB	Transmission request
			9	CSA	Transmission possible
			15	CSB	Transmission possible
			5		
SG	3		12	SG	Signal ground
		6	SG (Shield)		

(b) Connectors and connector covers used

① Connectors and connector covers connected to the GOT side

Name	Model name	Manufacturer
Connector cover	P1620A-CA (20)	Hirose Electric Co., Ltd.
Housing	SC-1620	
Contact	SC-1620	

② Connectors and connector covers connected to the upper link module side

Name	Model name	Manufacturer
Connector	XM2A-0901	Installed in the upper link module
Connector cover	XM2S-0911	

(c) Precaution items when creating cables

- ① The cable length must be within 200m (656.2 ft).
- ② Use electric wires of 20 core shield cable, and create cables by connecting two electric wires as shown in the (a) connection diagram.

2.10.2 System configuration when connecting to the C200H α series

(1) System configuration

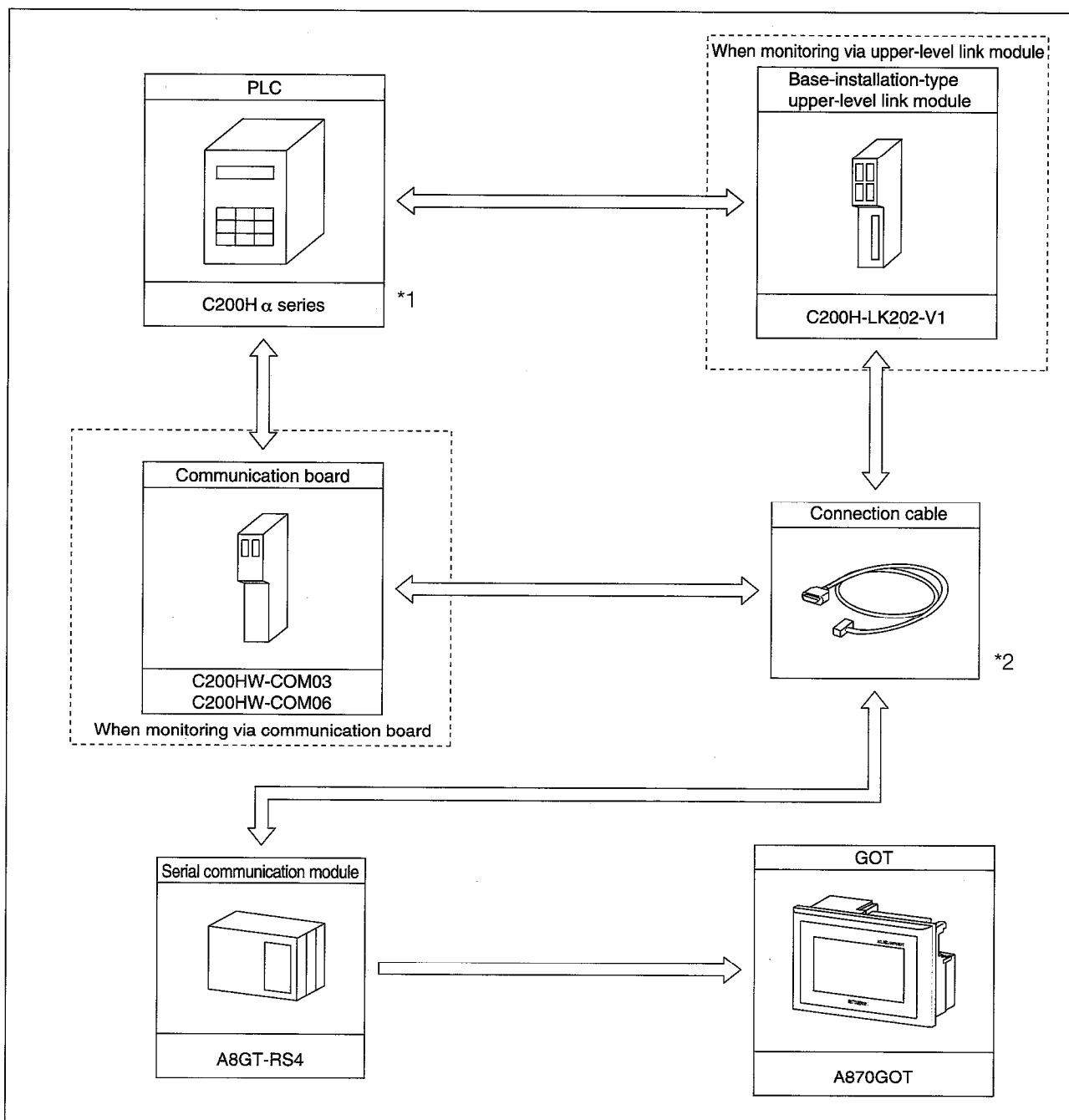

*1 : The communication board cannot be installed to the C200HE-CPU11. Install the board via upper-level link module.

*2 : The pin assignment of the connection cable is different for the communication board and for upper-level link module. (Refer to Section 2.1.4)

(2) Setting the upper-level link module switches

When using the upper-level link module (C200H-LK202-V1), perform the switch setting shown below.

Front panel switch setting

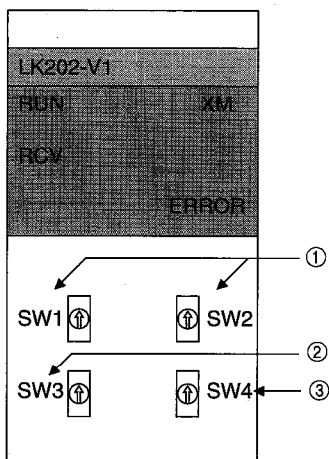

- ① Setting for SW1 and SW2 (Device No. setting)
Set as follows:
SW1:0, SW2:0 (Set to device No. 00.)
- ② Setting for SW3 (Transmission speed setting)
Set as follows:
SW3:6 (Set to 19.2 KBPS.)
- ③ Setting for SW4 (Command level/parity/transmission code setting)
Set as follows:
SW4:2 (Parity:even, transmission code: ASCII 7-bit, stop bit:2)

Back panel switch setting

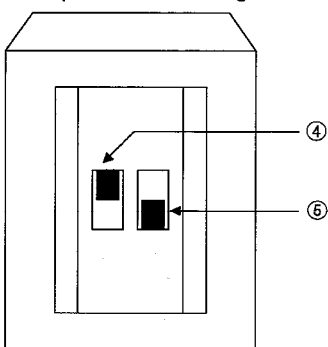

- ④ Setting for the terminator connection yes/no switch
Set to ON (exists).
- ⑤ Setting for 1 step/N steps setting
Set to OFF (N steps).

(3) About the communication board initialization program

When using the communication board, write the following values to the devices below, and perform initialization for port A of the communication board.

For the usage and initialization of each device, refer to the instruction manual of the specific communication board used.

Device name	Value to write	Device name	Value to write
DM6550 to DM6554	Write unnecessary	DM6555	0001H
DM6556	0304H	DM6557	0000H
DM6558	0000H	DM6559	0000H

(4) About the connection cable

The connection diagram and connectors for the cables connecting the GOT through the upper-level link module and communication board are shown below. (Max. cable length:200 m (7.87 ft.))

(a) Connection diagram

- ① Upper-level link module
- ② Communication board

Omron side				Cable connection and Signal direction	GOT side		Overview
Signal name		Pin No.			Pin No.	Signal name	
①	②	①	②				
SDA	5	2			8	RDA	Received data
SDB	9	1			14	RDB	Received data
RDA	1	8			10	SDA	Send data
RDB	6	6			16	SDB	Send data
					11	RSA	Send request
					17	RSB	Send request
					9	CSA	Send enabled
					15	CSB	Send enabled
					5		
SG	SHELL	3	SHELL		12	SG	Signal ground
			6		SG (Shield)		

(b) Connector and connectot cover

- GOT side connector

Name	Model	Manufacturer
Connector cover	P1620A-CA (20)	Hirose Electric Co., Ltd.
Housing	SC-1620	
Contact	SC-1600-11	

- Omron side connector

Use the connector supplied with the upper-level link module and the communication board.

2.10.3 System configuration when connecting to the CQM1

(1) System configuration

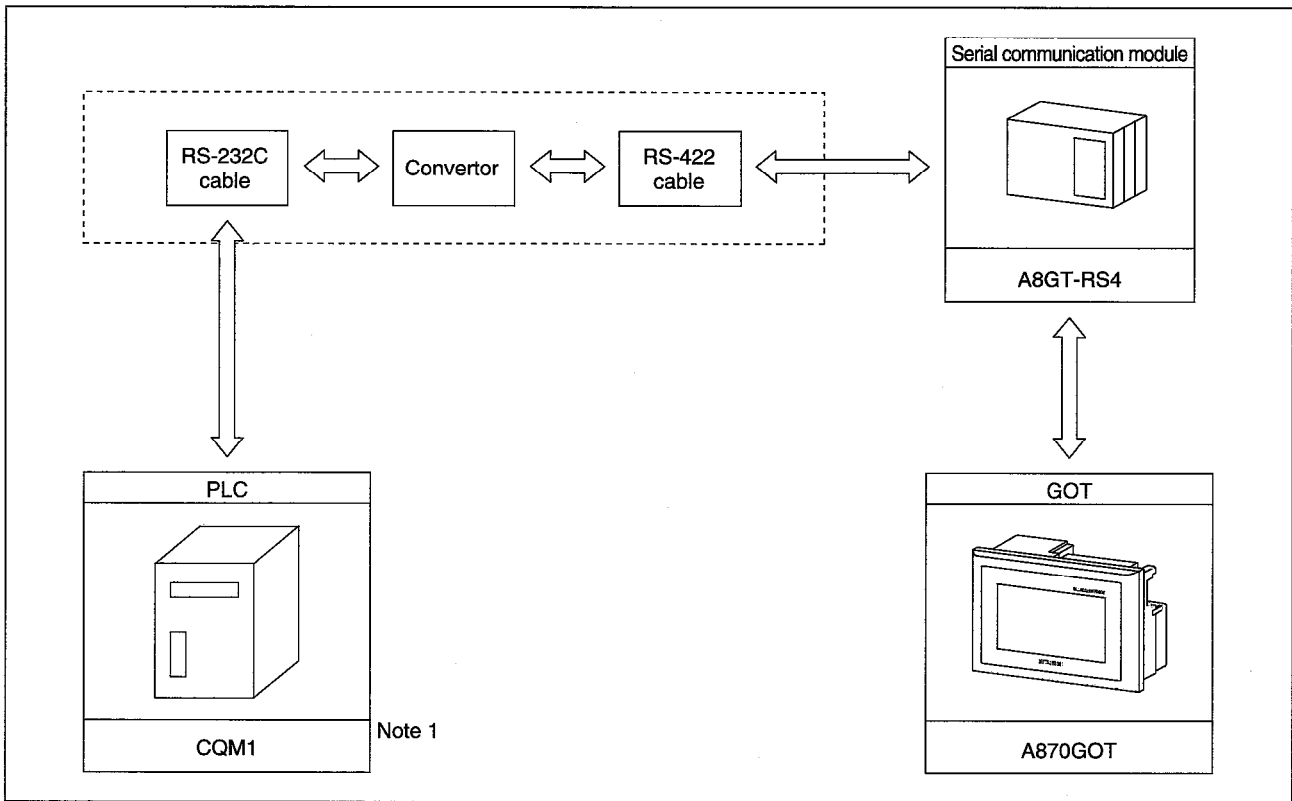

Note 1

Note 1: Since the CQM1-CPU11 does not have the RS-232C interface, it cannot be connected.

(2) About the CQM1 initialization

When using the RS232C port of the CQM1, write the values for the devices indicated below. Perform initialization for the RS232C port of the CQM1 using a peripheral tool or DM monitor. Refer to the CQM1 Instruction Manual for details.

Device name	Value to write	Device name	Value to write
DM6645	0001H	DM6646	0304H
DM6647	0000H	DM6648	0000H
DM6649	0000H		

(3) About the connection cable

The recommended convertor that can be used when connecting the CQM1 and the GOT, along with the connector and wiring, are indicated below. (Max. cable length: 200 m (7.87 ft.))

(a) Supported convertors

Model	Manufacturer
EL-LINE-II	EL Engineering
KS-10P	System Sacom, Ltd.

(b) Wiring connections when using EL-LINE-II

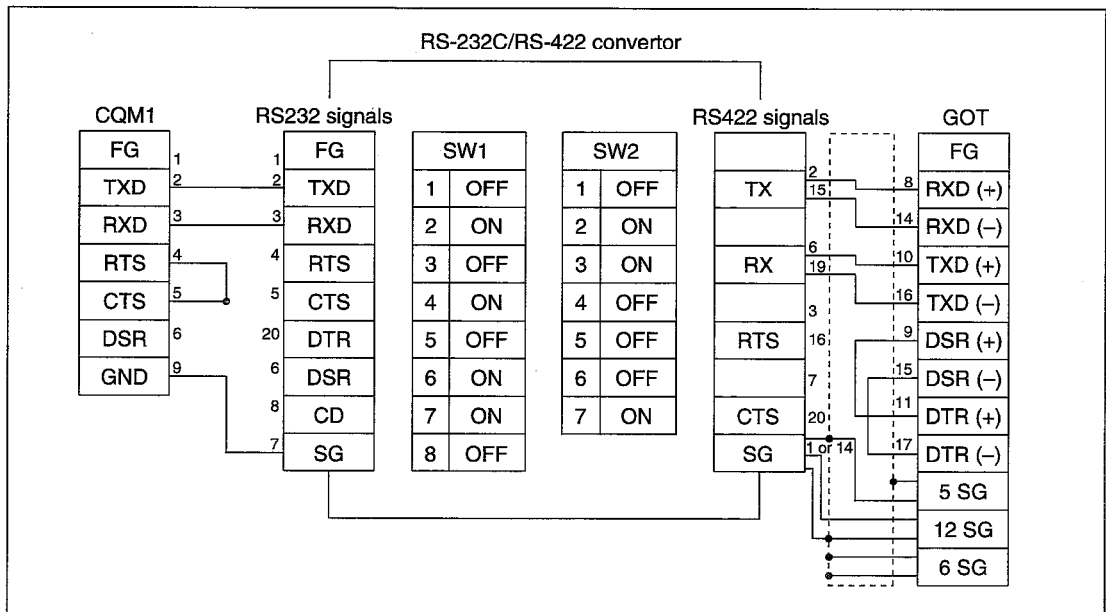

(c) Wiring when using KS-10P

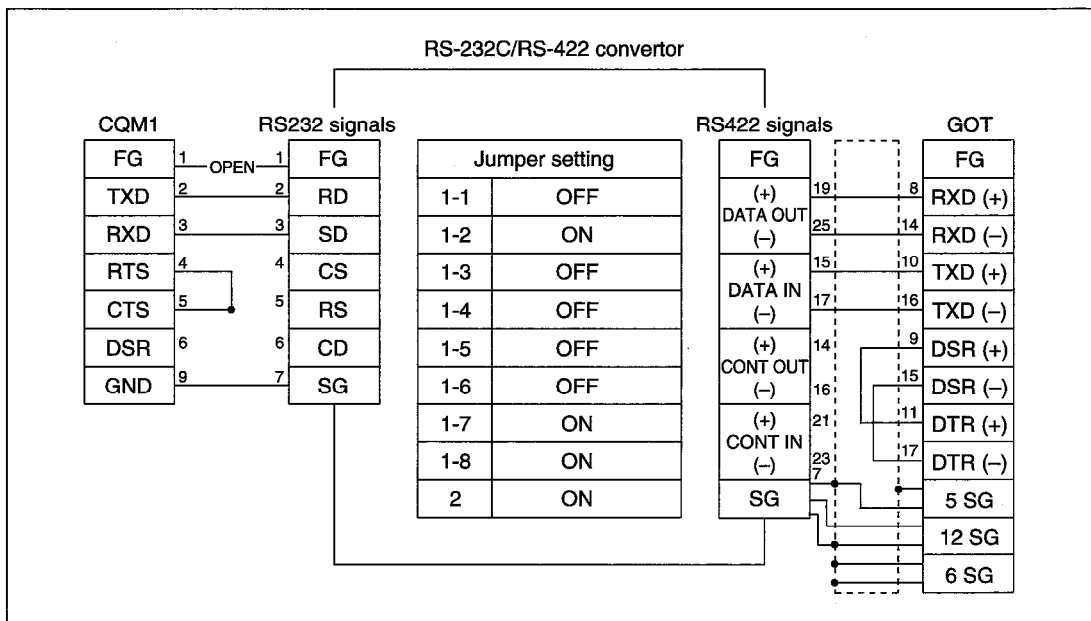

(4) Connectors

- CQM1 side connector
Use the connector provided with the CQM1.
- Connector for EL-LINE-II
RS-232C side connector: 25-pin D sub (male), screw type
RS-422C side connector: 25-pin D sub (female), screw type
- Connector when using the KS-10P
RS-232C side connector: 9-pin D sub (male), screw type
RS-422C side connector: 25-pin D sub (female), screw type
- GOT side connector

Name	Model	Manufacturer
Connector cover	P1620A-CA (20)	Hirose Electric Co., Ltd.
Housing	SC-1620	
Contact	SC-1600-11	

2.10.4 System configuration when connecting to the C1000H and C2000H

(1) System configuration

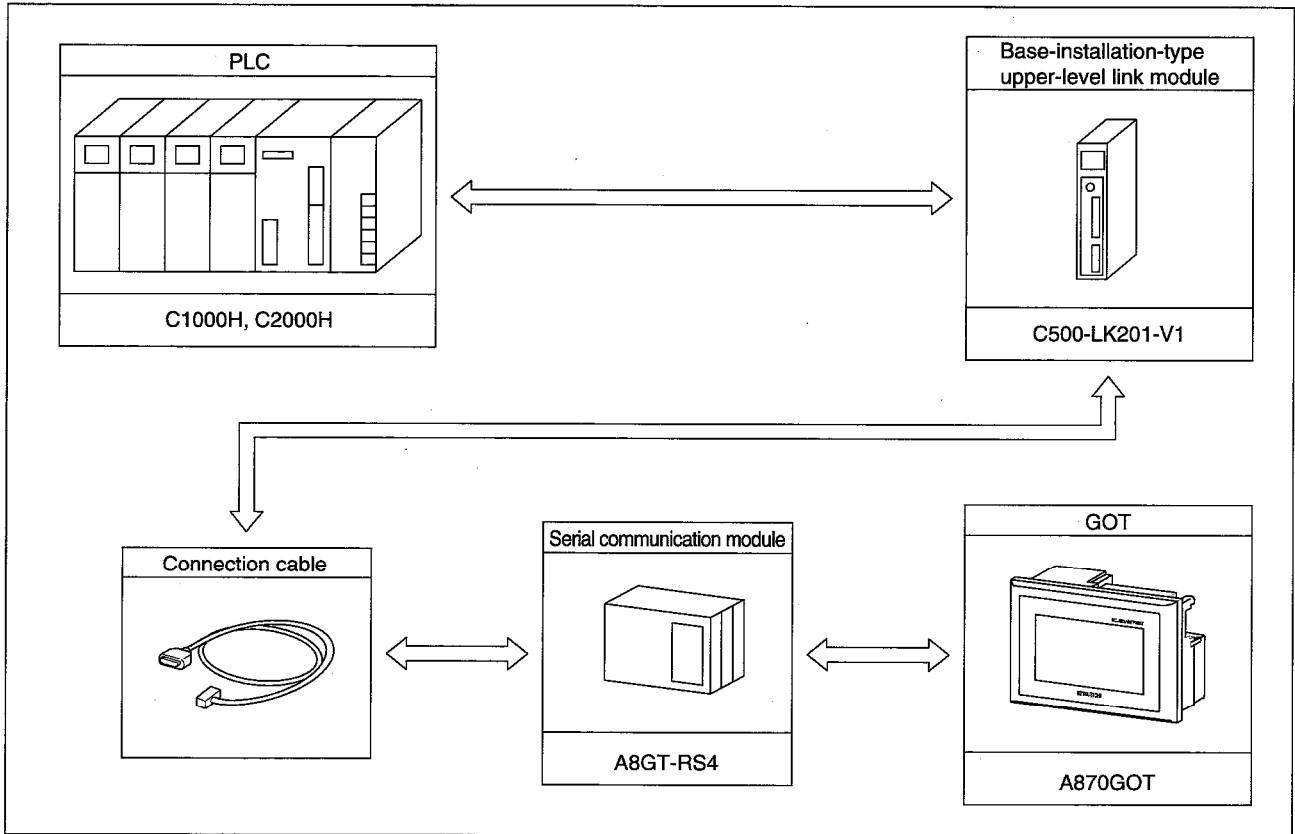

(2) Upper level link module switch setting

Perform the following switch settings for the upper level link module (C500H-LK201-V1).

Front panel switch setting

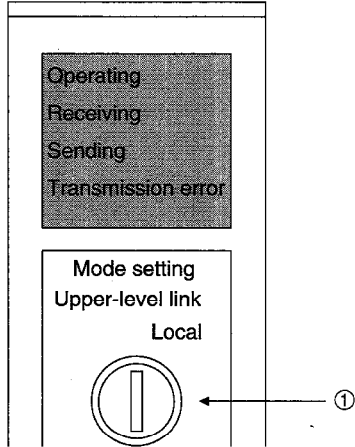

- ① Upper level link/local setting
Set to upper-level link.

Back panel switch setting

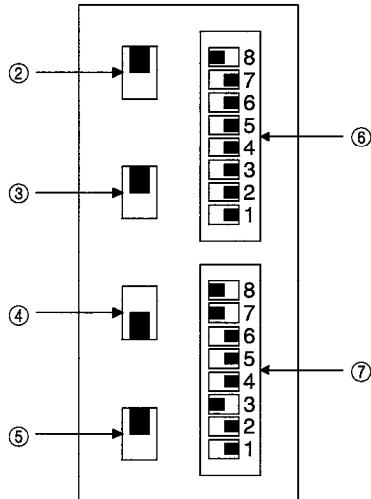

- ② RS-232C/RS-422 switch setting
Set to RS-422 (top).
- ③ Internal/external colck switch setting
Set to internal (top).
- ④ Terminal resistor connection yes/no switch setting
Set to yes (bottom).
- ⑤ CTS switch setting
Set to 0V (top).
- ⑥ SW1 setting (Device No., operate/stop setting)
Set as the following:

1	2	3	4	5	6	7	8
OFF	OFF	OFF	OFF	OFF	OFF	OFF	ON

Device No.00
Operation

- ⑦ SW2 setting (Transmission speed, 1 step/N steps, level setting)

1	2	3	4	5	6	7	8
OFF	OFF	ON	OFF	OFF	OFF	ON	ON

19.2KBPS
N steps
Level 1,2, and 3 valid

(3) About the connection cables

The connection diagram of the cables connecting the upper-level link module and GOT, and the connectors used are shown below. (Max. cable length: 200 m (7.87ft.))

(a) Connection diagram

Omron side		Cable connection and Signal direction	GOT side		Overview
Signal name	Pin No.		Pin No.	Signal name	
SDA	5		8	RDA	Receive data
SDB	9		14	RDB	Receive data
RDA	1		10	SDA	Send data
RDB	6		16	SDB	Send data
			11	RSA	Send request
			17	RSB	Send request
			9	CSA	Send enabled
			15	CSB	Send enabled
			5		
SG	3		12	SG	Signal ground
		6	SG (Shield)		

(b) Connector and connector cover

- GOT side connector

Name	Model	Manufacturer
Connector cover	P1620A-CA (20)	Hirose Electric Co., Ltd.
Housing	SC-1620	
Contact	SC-1600-11	

- Omron side connector

Use the connector provided with the upper-level link module.

2.10.5 System configuration when connected to CV1000

(1) System configuration

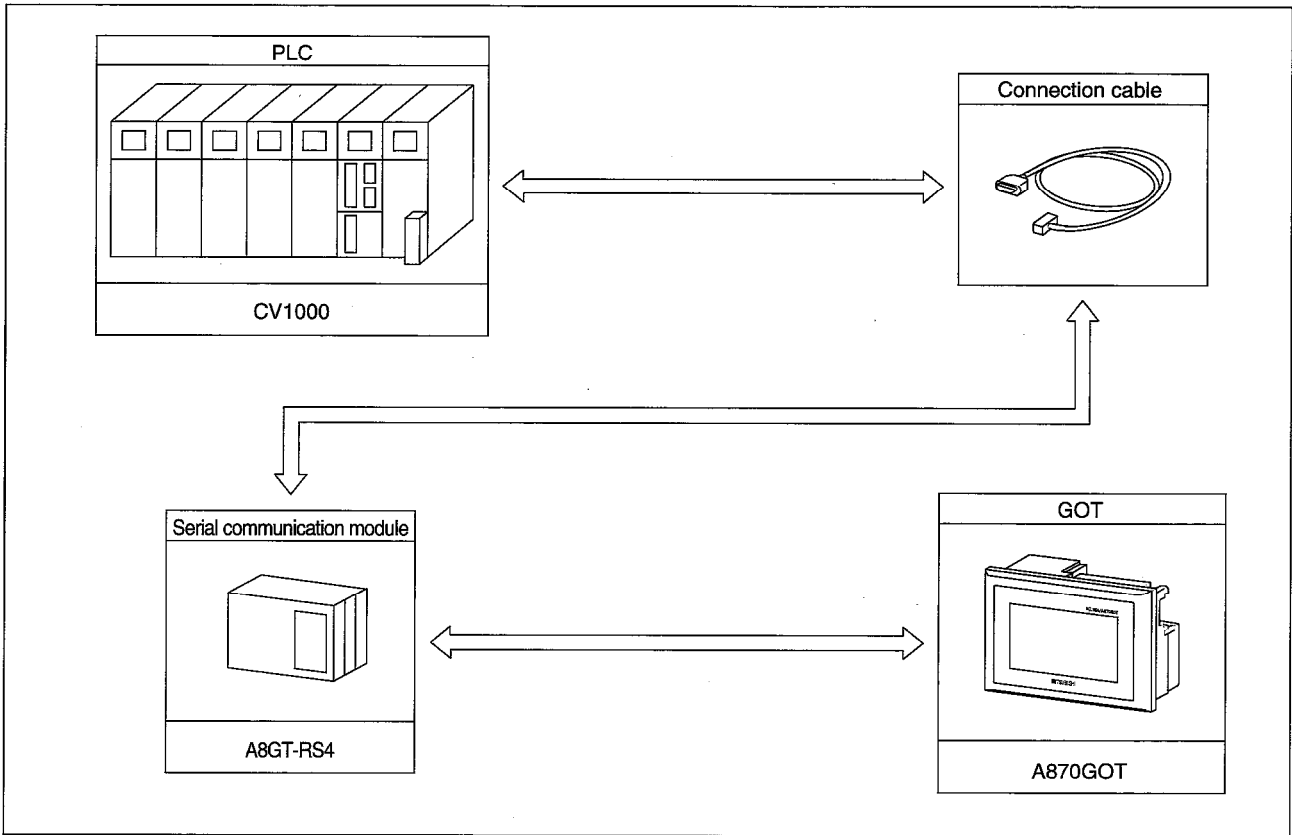

(2) CPU switch setting

Set the switches to the following for the CPU (CV1000).

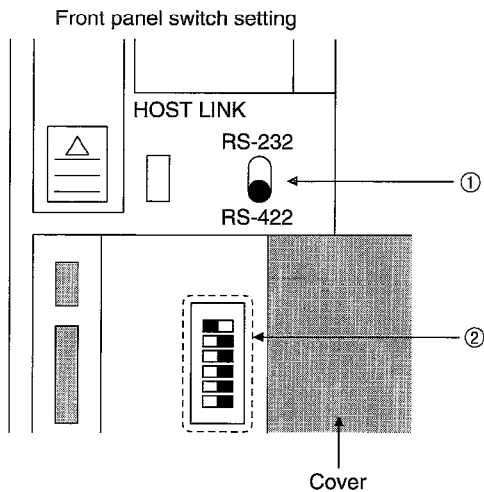

① RS-232/RS-422 switch setting

Set to RS-422 (bottom).

② DIP switch setting

Set as the following:

1	2	3	4	5	6
OFF	OFF	OFF	OFF	OFF	ON

Setting mandatory

(3) CPU setting by peripheral tool

Set the following to the CPU (CV1000) using a peripheral tool:

Item	Set value
Transmission speed	19200BPS
Stop bit	2 stop bits
Parity	Even parity
Data length	7 bits
Device No.	Device No.00

(4) About the connection cables

The connection diagram of the cables connecting the CPU (CV1000) and the GOT, and the connectors used are shown below. (Max. cable length: 200 m(7.87 ft.))

(a) Connection diagram

Omron side		Cable connection and Signal direction	GOT side		Overview
Signal name	Pin No.		Pin No.	Signal name	
SDA	2		8	RDA	Receive data
SDB	1		14	RDB	Receive data
RDA	8		10	SDA	Send data
RDB	6		16	SDB	Send data
			11	RSA	Send request
RS	4		17	RSB	Send request
CS	5		9	CSA	Send enabled
			15	CSB	Send enabled
			5		
SHELL			12	SG	Signal ground
		6	SG (Shield)		

(b) Connector and connector cover

- GOT side connector

Name	Model	Manufacturer
Connector cover	P1620A-CA (20)	Hirose Electric Co., Ltd.
Housing	SC-1620	
Contact	SC-1600-11	

- Omron side connector

Use the connector provided with the CPU (CV1000).

2.11 System Configuration When Connecting to the Microcomputer

2.11.1 Overview

Point

- When connecting to the microcomputer, the expansion functions (system monitor function, circuit monitor function, special module monitor function) cannot be used.)

The GOT virtual device (D) can be monitored from the PC, microcomputer board, PLCs, etc., (abbreviated as host from this point on) by sending/receiving data.

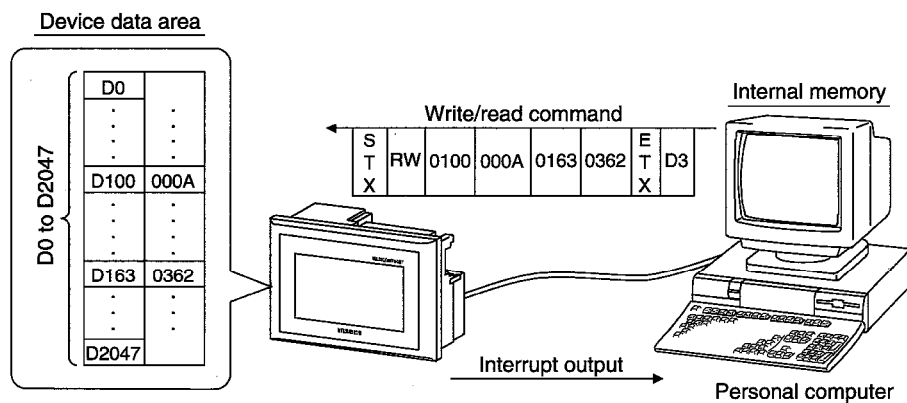

* When installing the OS to the GOT, install the communication driver "Computer" as well.

2.11.2 System configuration

The system configuration when connecting to the microcomputer is shown below.

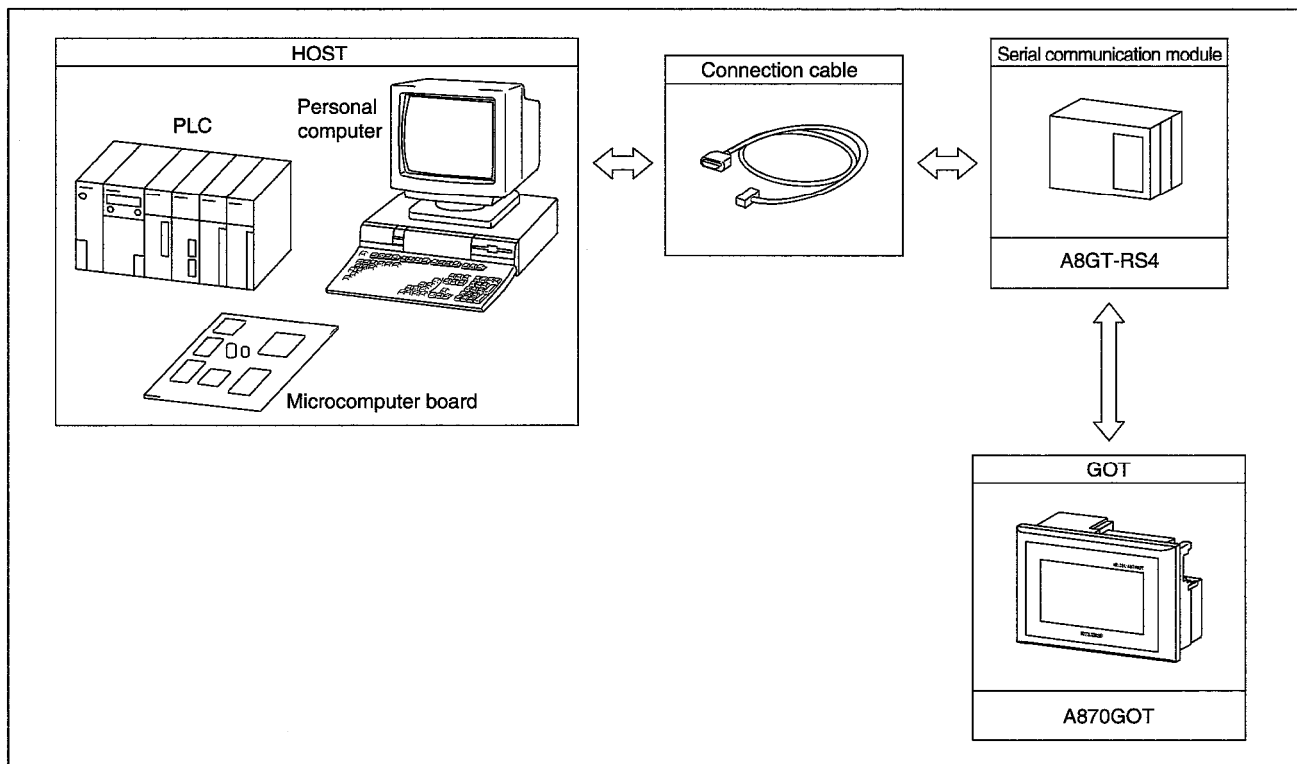

2.11.3 About the connection cables

(1) When connecting the DTR

The connection diagram of the cables for the host and GOT when connecting the DTR signals, and the connectors used are shown below.

(a) Connection diagram

Host side Signal name	Cable connection and Signal direction	GOT side		Overview
		Pin No.	Signal name	
SDA		8	RDA	Receive data
SDB		14	RDB	Receive data
RDA		10	SDA	Send data
RDB		16	SDB	Send data
DSR+		11	RSA	Send request (DTR+)
DSR-		17	RSB	Send request (DTR-)
DTR+		9	CSA	Send enabled (DTR+)
DTR-		15	CSB	Send enabled (DTR-)
		5		
SG		12	SG	Signal ground
		6	SG (Shield)	

DSR signal When the signal is off, the send is not performed from the GOT to the host. Normally, send signals from the host so that the DSR is always turned on.

DTR signal The signal turns on when the GOT can receive data.

(b) Connector and connector cover

- GOT side connector

Name	Model	Manufacturer
Connector cover	P1620A-CA (20)	Hirose Electric Co., Ltd.
Housing	SC-1620	
Contact	SC-1600-11	

- Host side connector

Use the connector compatible with the host used.

(2) When not connecting the DTR

The connection diagram of the cables for the host and GOT when not connecting to the DTR signals, and the connectors used are shown below.

(a) Connection diagram

Host side Signal name	Cable connection and Signal direction	GOT side		Overview
		Pin No.	Signal name	
SDA		8	RDA	Receive data
SDB		14	RDB	Receive data
RDA		10	SDA	Send data
RDB		16	SDB	Send data
		11	RSA	Send request (DTR+)
		17	RSB	Send request (DTR-)
		9	CSA	Send enabled (DTR+)
		15	CSB	Send enabled (DTR-)
		5		
SHELL		12	SG	Signal ground
	6	SG (Shield)		

(b) Connector and connector cover

- GOT side connector

Name	Model	Manufacturer
Connector cover	P1620A-CA (20)	Hirose Electric Co., Ltd.
Housing	SC-1620	
Contact	SC-1600-11	

- Host side connector

Use the connector compatible with the host used.

2.11.4 Transmission specification

The transmission specification when communicating between the GOT and the host is shown below.

Data bit	7 bits
Parity bit	Yes (Even)
Stop bit	1 bit
Sum check	Yes
Trasmission speed	19200BPS

2.11.5 Communication commands

The commands used for communication are described.

(1) When connecting the DTR

The list of commands used for the data transmission between the GOT and the host are shown below.

Command	Command name	Description
RD	Batch read command	Reads data for the specified number of points from the specified device continuously.
WD	Batch write command	Writes data for the specified number of points to the specified device continuously.
RR	Random read	Reads data from multiple device addresses.
RW	Random write	Writes data to multiple device addresses.

(2) Data communication format

The data communication format used in the command is shown below.

(a) Format for data send (Host → GOT)

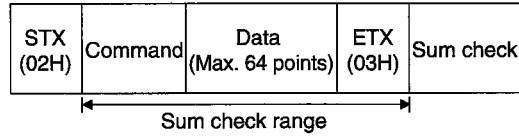

(b) Response data format during normal communication (GOT → Host)

- When sending read command (RD, RR)

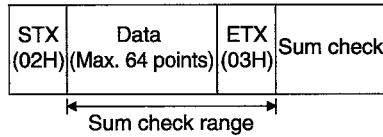

- When sending write command (WD, RW)



(c) Response data format when an error occurs (GOT → Host)



(3) Precautions when using the communication commands

- The sum check code is the lower 1-byte (8 bits) value of the sum of the data in the sum check range in binary.

(Example) When reading address D 100 to D101 using the RD command:

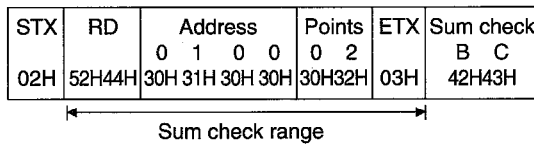

Formula: $52H+44H+30H+31H+30H+30H+30H+32H+03H = 1\underline{BC}H$

(4) Batch read command (RD)

The contents of batch read command is shown below.

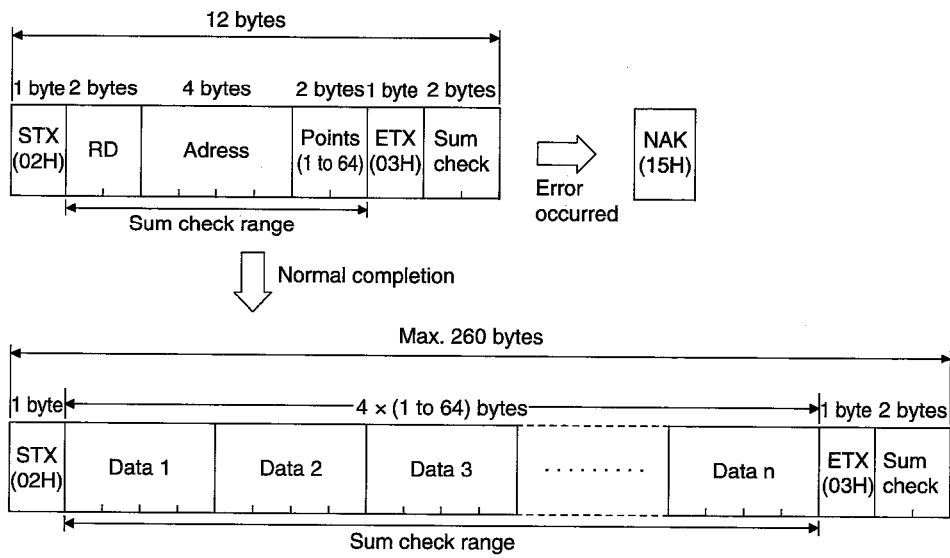

Usage example

When reading D100 to D102 in the GOT virtual device:

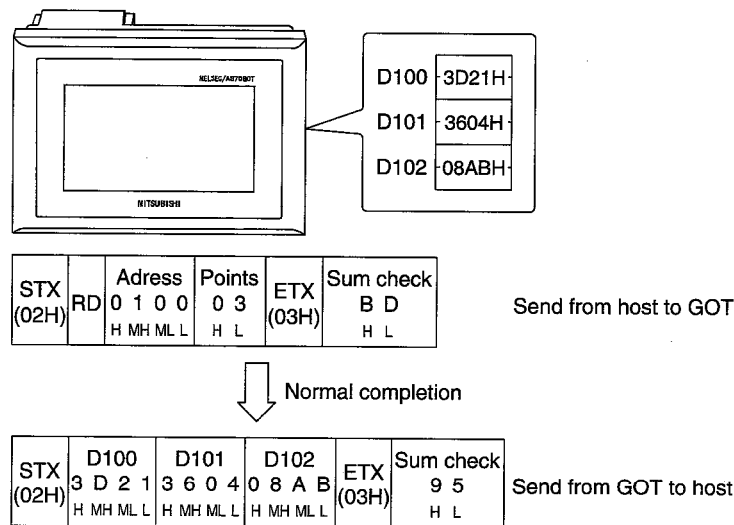

(5) Batch write command (WD)

The details of the batch write command is shown below.

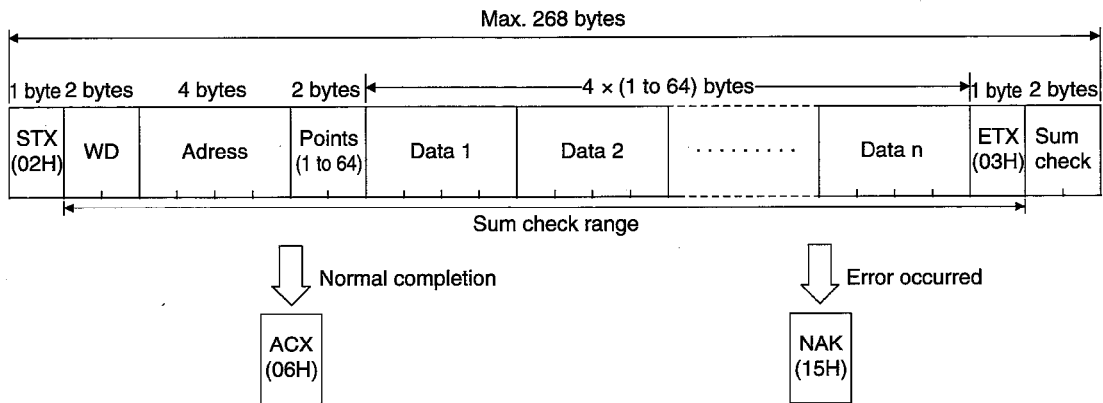

Usage example

When writing 64H and 65H into the GOT virtual device D100 to D101:

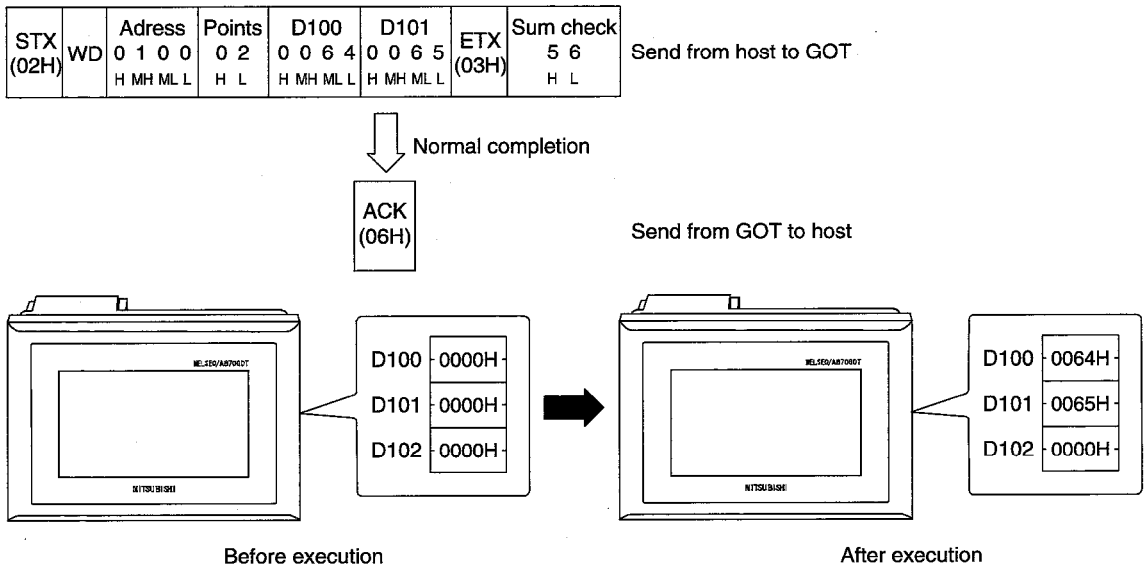

(6) Random read command (RR)

The details of the random read command is described below.

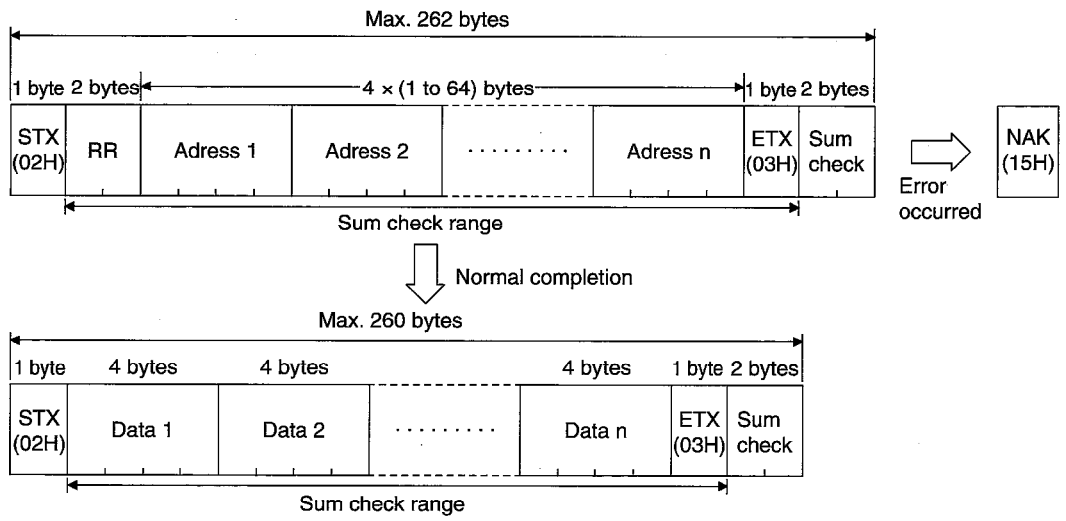

Usage example

When reading D100, D26 and D163 in the GOT virtual device :

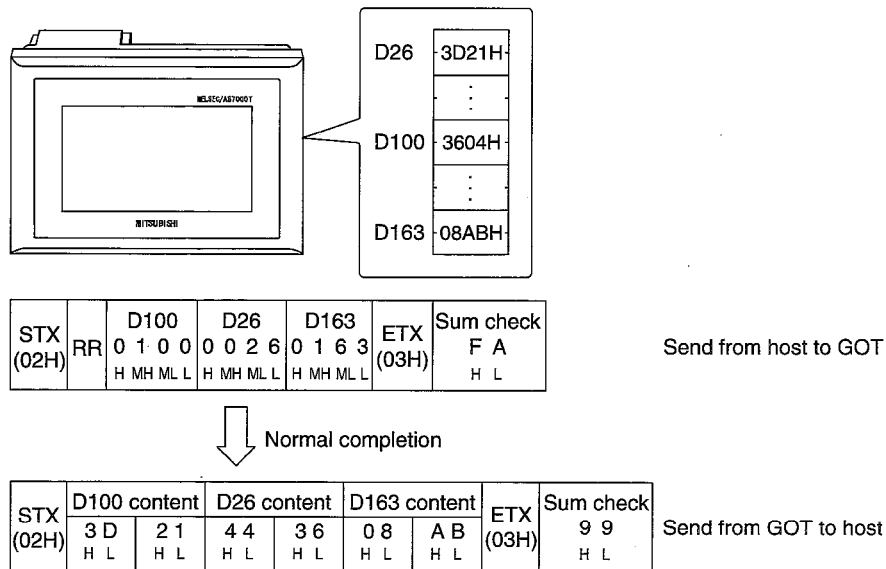

(7) Random write command (RW)

The details of the random write command is indicated below.

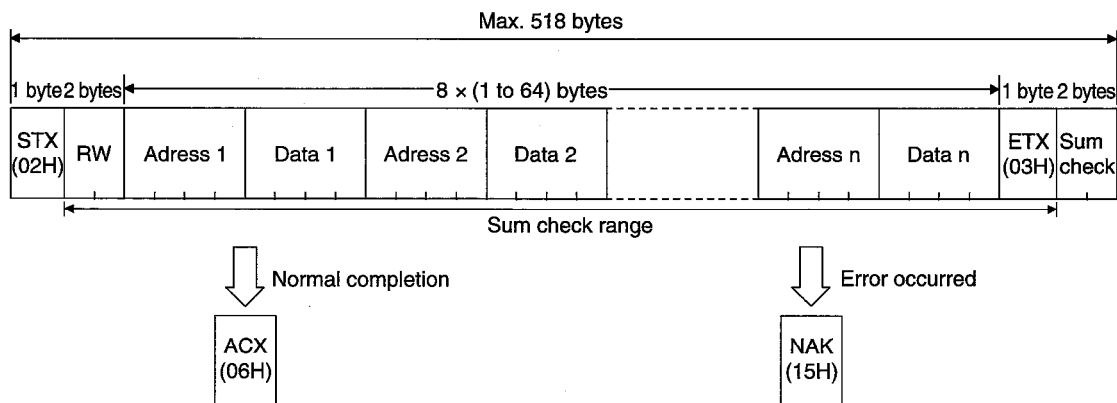

Usage example

When 8BH and 44H into the GOT virtual device D30 and D100 respectively :

STX (02H)	RW	D30	D30 data	D100	D100 data	ETX (03H)	Sum check
		0 0 3 0	0 0 8 B	0 1 0 0	0 0 4 4		D 2
		H MH ML L	H MH ML L	H MH ML L	H MH ML L		H L

Send from host to GOT

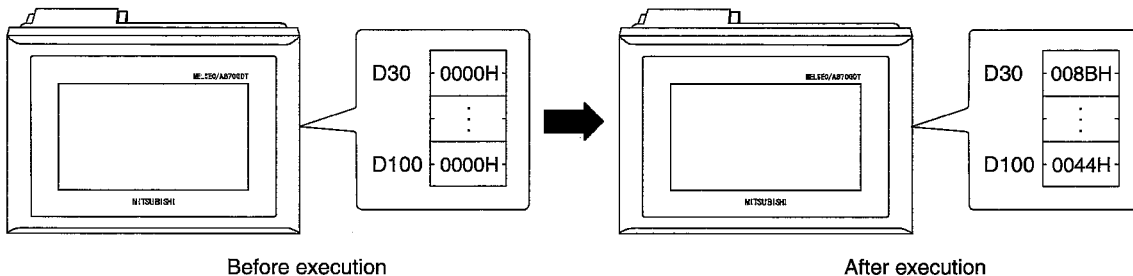
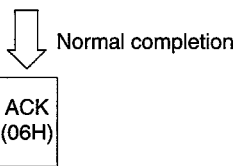

3. Specifications

3.1 General Specifications

The specifications that are common to all of the various modules are listed below.

Item	Specifications				
Ambient operating temperature	Display module		Other than display module		
	0 to 40°C		0 to 55°C		
Ambient storage temperature	A8GT-70GOT-EW, A8GT-70GOT-EB		-20 to 5°C		
	A8GT-70GOT-SW, A8GT-70GOT-SB A8GT-70GOT-TW, A8GT-70GOT-TB		-20 to 60°C		
Ambient operating humidity	10 to 90% RH, with no condensation				
Ambient storage humidity	10 to 90% RH, with no condensation				
Vibration resistance	JIS B 3501, Conforming to IEC 1131-2	Under intermittent vibration			10 times each in X, Y, Z directions (for 80 min.)
		Frequency	Acceleration	Amplitude	
		10 to 57Hz	—	0.075 mm (0.003 inch)	
		57 to 150Hz	9.8 m/S ² {1G}	—	
		Under continuous vibration			
		Frequency	Acceleration	Amplitude	
		10 to 57Hz	—	0.035 mm (0.001 inch)	
		57 to 150Hz	4.9 m/S ² {0.5G}	—	
Impact resistance	Conforming to JIS B 3501, IEC 1131-2 (147 m/s ² {15 G}), 3 times in each of 3 directions				
Environment	No corrosive gases				
Altitude	2000 m (6562 feet) max.				
Installation location	Control panel				
Over-voltage category *1	II max.				
Pollution level *2	2 max.				

*1. This indicates the section of the power supply to which the equipment is assumed to be connected between the public electrical power distribution network and the machinery within the premises. Category II applies to equipment for which electrical power is supplied from fixed facilities. The surge voltage withstand level for up to the rated voltage of 300 V is 2,500V.

*2. This index indicates the degree to which conductive material is generated in terms of the environment in which the equipment is used. Pollution level 2 indicates that only non-conductive pollution is produced; however, in this environment, there may be times when temporary conductivity is produced because of freezing.

3.2 Performance Specifications

3.2.1 GOT main module

Item		Specifications		
		A8GT-70GOT-EW, A8GT-70GOT-EB	A8GT-70GOT-SW, A8GT-70GOT-SB	A8GT-70GOT-TW, A8GT-70GOT-TB
Display unit	Type	EL	STN color LCD, with backlights	TFT color LCD, with backlights
	Resolution	Horizontal: 640 dots, vertical: 400 dots	Horizontal: 640 dots, vertical: 480 dots	
	Display size	120 mm (vertical) x 192 mm (horizontal) (4.7 inch) (7.6 inch)	158 mm (6.2 inch) (vertical) x 211 mm (8.3 inch) (horizontal)	
	Display color	Single color (yellow/orange, black), no gray scale	8 colors	15 colors
Backlights		—	Chilled cathode ray tube backlight Backlights can be replaced	
Touch panel	No. of touch keys	1000 (25 rows x 40 columns)	1200 (30 rows x 40 columns)	
	Key size	16 dots x 16 dots (per key)		
	Repeat function	None		
Memory *1	Type	Internal memory (flash ROM)		
	Application	For storing project data/for storing OS		
	Capacity	Maximum 768 KB (user area) (Can be expanded to a maximum of 4864 KB by installing an expansion memory cassette.)		
RS-232C interface		For connecting personal computer; 1 channel		
Memory card interface		For installing memory card conforming to JEIDA Ver. 4.0 standards; 1 channel		
Interface for memory cassette connection		For connecting memory cassette; 1 channel		
Interface for connecting communications module		For connecting communications module; 1 channel		
Interface for connecting optional module		For connecting printer interface module/external I/O interface module; 1 channel		
Buzzer		Single sound (length of sound can be adjusted)		
Lifetime *2	Display module	30,000 Hr (70% of initial brightness)	50,000 Hr	41,000 Hr
		Ambient temperature when used is 25°C		
	Backlights	—	10,000 Hr (display module is 50 %)	25,000 Hr (display module is 50 %)
	Touch keys	1 million times min. (at operational force of 100 g (0.2 lb) or less)		
Internal memory		No. of writings: 100,000		
I/O allocation		32 special points (for bus connection only)		
Environmental protection construction		IP65 or equivalent (front panel section)		
External dimensions (without power supply module)		210 mm (H) x 285 mm (W) x 98 mm (D) (8.3 inch) (11.2 inch) (3.9 inch)	230 mm (H) x 320 mm (W) x 92 mm (D) (9.1 inch) (12.6 inch) (3.6 inch)	
Weight (without power supply module)		1.7 kg (3.7 lb)	1.9 kg (4.2 lb)	1.8 kg (4.0 lb)

*1. The internal memory is a ROM which enables overwriting of new data without deleting previously written data.

(No data backup power supply is required.)

*2. When parts need to be replaced, please consult your nearest dealer or branch office.

NOTE

With the GOT, if a momentary power failure occurs, the screen display disappears. If the power is restored within 20 ms, however, monitor functions and other functions resume normal operation.

3.2.2 Power supply module

Item	Specifications		
	A8GT-PWEL	A8GT-PWST	A8GT-PWTF
Applicable GOT	A8GT-70GOT-EW, A8GT-70GOT-EB	A8GT-70GOT-SW, A8GT-70GOT-SB	A8GT-70GOT-TW, A8GT-70GOT-TB
Input power supply voltage	AC100 to 120V (+10%, -15%)/200 to 240V (+10%, -15%)		
Input frequency	50/60HZ (±3%)		
Max. input apparent power	100VA		
Surge current	20A max. (264V AC, max. load)		
Allowable momentary power failure	Within 20 ms		
Noise withstand volume	Noise voltage 1500 Vpp, noise width 1 μs, noise frequency 25 to 60Hz, based on noise simulation		
Voltage withstand resistance	Between AC external terminal group and ground: 1500V AC, for 1 minute Between DC external terminal group and ground: 500V AC, for 1 minute		
Insulation resistance	Between AC external terminal group and ground: 500V DC, 5 MΩ min. by means of insulation resistance		
External output *3	Transistor output: 2 points (RUN, OUTPUT)		
Compatible power cable size	0.75 to 2 mm ²		
Compatible crimping terminal	V1.24-4, V1.25-YS4A, V2-S4, V2-YS4A		
Compatible tightening torque	118 N·cm (12 kg·cm)		
External dimensions	182 mm (7.2 inch) (H) x 98 mm (3.9 inch) (W) x 50 mm (2.0 inch) (D)		
Weight	450 g (1.0 lb)		

*3. ① External output specifications

Item		Specifications
Insulation method		Photocoupler insulation
Usable load voltage range		10.2 to 30V DC
Max. load current		0.5 A/point, 1A/1 common
Max. surge current		1A, 100 μs max.
Leakage current when off		0.1 mA max.
Max. drop in voltage when on		0.9V DC (typ.), 0.5A, 1.5V DC (max.), 0.5A
Response time	OFF → ON	2 ms max.
	ON → OFF	2 ms max. (resistance load)
Surge killer		Zener diode built into photocoupler
Externally supplied power	Voltage	12/24C DC (10.2 to 30V DC)
	Current	7 mA (typ., 24V DC, per common)

② Using external output

- RUN This outputs a signal indicating whether or not the GOT is operating normally.

Output status)

ON : when operating normally

OFF : when an error occurs

(wiring diagram: see Section 4.2)

This should be used in instances where the GOT operation is being monitored by the PC CPU. This function is used by having the external output read by an input module and then having it checked by the sequence program.

- OUTPUT By turning on the GOT's internal bit device GB1 using the status monitoring function or the touch switch (bit) function, an external output (lamp illumination, buzzer) is available.

In order to use this function, install version B or later of the ROM_BIOS/OS for SW2NIW-A8SYSP to the GOT.

3.3 Supported CPU

(1) Supported CPU

Large-sized MELSEC-A series/QnA series CPU	Q2ACPU, Q2ACPU-S1 Q3ACPU, Q4ACPU Q4ARCPU A1NCPU, A2NCPU, A2NCPU P21/R21 A3NCPU, A3NCPU P21/R21 (Version L or later for AnNCPU with link, version H or later for AnNCPU without link) A2UCPU, A2UCPU-S1 A3UCPU, A4UCPU A2ACPU, A2ACPU P21/R21 A2ACPU-S1, A2ACPU-S1 P21/R21 A3ACPU, A3ACPU P21/R21
Small-sized MELSEC-A series /QnA seriesCPU	Q2ASCPU, Q2ASHCPU, A2USCPU, A2USCPU-S1, A2USHCPU, A2USH-S1 A1SCPU, A1SHCPU A2SCPU (Version C or later for A2SCPU)*1 A2SHCPU A1SJCPU, A1SJHCPU, A1SJCPU-S3 A0J2HCPU (Version E or later) A2CCPU (Version H or later)*2 A2CJCPU*2
Multi-axis controller CPU	A273UCPU, A273UHCPU A373UCPU A171SCPU, A171SCPU-S3
MELSEC-FX series CPU	FX ₀ series, FX _{0N} series, FX _{0S} series, FX ₁ series, FX ₂ series, FX _{2C} series, FX _{2N} series *3
PLC by Omron	C200H series, C200HS series, C200Hα series, CQM1 series, C1000H series C2000H series CV1000 series *4
Microcomputer connection	Personal computer, microcomputer board, PLC, etc.

*1 Calculator link connections are not available for A2S.

*2 Bus connections are not available for A2C or A2CJCPU.

*3 The FX_{2N} series monitor possible range is the FX_{2C} series device range.

*4 For CV1000, use the PLC version V1 or later.

(2) Restriction of the clock function

Among the application CPUs listed in (1), the CPUs that can not be supported the clock functions (Utility screen clock setting function, Clock display function, Date display in the alarm list /alarm history display function, Date and time print in the report function) are shown below.

- ① MELSEC-A and QnA series
A0J2HCPU, A2CCPU, A2CJCPU
- ② MELSEC-FX series, Omron PLC, microcomputer connections

Model		Clock function	
MELSEC-FX series	FX ₀ series, FX _{0N} series FX _{0S} series, FX ₁ series	Unusable	
	FX ₂ series, FX _{2C} series	The clock function can be used when the real-time clock cassette is used.	
	FX _{2N} series	Usable	
	C200H-CPU11 C200H-CPU31	Usable	
Omron PLC	C200H series	C200H-CPU21 C200H-CPU22 C200H-CPU23	Clock function can be used when using the clock-function memory cassette is used
		C200H-CPU01 C200H-CPU02 C200H-CPU03	Unusable
	C200HS series		Usable
	C200H α series	C200HE-CPU11	Unusable
		PLC other than above	Usable
	CQM1 series		Clock function can be used when using the colck-function memory cassette is used
	C1000H and C2000H series		Unusable
	CV1000		Unusable
	Microcomputer connection		Unusable

3.4 Monitor Functions that can be Used with Each Connection Method

The monitor functions that can be used with each connection method are shown below. For information regarding applicable CPUs refer to Section 3.3. For details regarding the expansion function (system monitor function, special module monitor function, circuit monitor function), refer to the A870G0T/A85□GOT Operating Manual (Expanded Functions Manual).

1 When the monitor destination is the MELSEC-A series or QnA series.

Function Name Connection Type		Sprite Function		System Monitor Function (Note 3)		Special Module Monitor Function		Circuit Monitor Function	
		Monitored PC CPU Type							
		ACPU	QnACPU	ACPU	QnACPU	ACPU	QnACPU	ACPU	QnACPU
CPU direct connection	Connected station (local station)	○	○	○	○	○	○	○	×
	Remote station	○*1	○*1	○*1	○*1	○*4	○*4	○	
Bus connection	Connected station (local station)	○	○	○	○	○	○	○	
	Remote station	○*1	○*1	○*1	○*1	○*4	○*4	○	
Calculator link connection	Connected station (local station)	○	○	○	○	×	○	○*4	
	Remote station	○*1	○*1	○*1	○*1	○*1	○*4	○*4	
MELSECNET (II)/B connection	Master station	○	○*2	○	○*2	○	×	○	
	Local station	×	×	×	×	×		×	
MELSECNET /10 connection	Control station	○	○	○	○	○		○	○
	Normal station	○*1	○*2	○*1	○*2	○*4		○	○

- *1. There are times when monitoring is not conducted by the PC CPU that is being monitored. For details refer to SW2NIW-A8GOTP Operating Manual (Monitor Screen Creation Manual).
- *2. Monitors other than B and W allocated by the link parameter/network parameter are in the AnA device range.
- *3. When the monitor destination is QnACPU, the T/C set value cannot be performed to monitor or change. The monitor destination cannot be performed to change V/Z current value regardless of the ACPUs or QnACPU. When the monitor destination is QnACPU, the device comment cannot be performed to display.
- *4. This is done by installing a special module monitor function OS of the SW2NIW-A8SYSP version D or later.

2 When the monitor destination is MELSEC-FX series, Omron PLC, or microcomputer connection

The access range that can be monitored are only the connected CPU and PLC. Remote stations cannot be monitored.

Function Name Connection Type	Sprite Function	System Monitor Function	Special Module Monitor Function	Circuit Monitor Function
MELSEC-FX series connection	○	○ *1	×	×
Omron PLC connection	○	×	×	×
Microcomputer connection	○	×	×	×

- *1. This is done by installing a system monitor function OS of the SW2NIW-A8SYSP version B or later.

3.6 Table of Component Equipment Modules

Component	Model	Remarks	
GOT set component (GOT main module + power supply module)	A870GOT-EWS	A8GT-70GOT-EW (main module) and A8GT-PWEL (power supply) set components	
	A870GOT-SWS	A8GT-70GOT-SW (main module) and A8GT-PWST (power supply) set components	
	A870GOT-TWS	A8GT-70GOT-TW (main module) and A8GT-PWTF (power supply) set components	
GOT main module	A8GT-70GOT-EW	EL display module with touch key panel (case color: ivory white)	
	A8GT-70GOT-EB	EL display module with touch key panel (case color: dark gray)	
	A8GT-70GOT-SW	STN color LCD display module with touch key panel (case color: ivory white)	
	A8GT-70GOT-SB	STN color LCD display module with touch key panel (case color: dark gray)	
	A8GT-70GOT-TW	TFT color LCD display module with touch key panel (case color: ivory white)	
	A8GT-70GOT-TB	TFT color LCD display module with touch key panel (case color: dark gray)	
Power supply module	A8GT-PWEL	100/200 VAC input for EL display module	
	A8GT-PWST	100/200 VAC input for STN color LCD module	
	A8GT-PWTF	100/200 VAC input for TFT color LCD module	
Backlights	A8GT-70LTS	Set of 2 for STN color LCD module	
	A8GT-70LTT	For TFT color LCD module	
Protective sheet	A8GT-70PSCE	Set of 5 transparent protective sheets for EL	
	A8GT-70PSNE	Set of 5 anti-reflection protective sheets for EL	
	A8GT-70PSCS	Set of 5 transparent protective sheets for STN/TFT	
	A8GT-70PSNS	Set of 5 anti-reflection protective sheets for STN/TFT	
Expanded memory cassette	A8GT-MCA1MFDW	Internal memory expansion 1M byte (For OS and user screens)	One of these is necessary when monitoring circuits.
	A8GT-MCA2MFDW	Internal memory expansion 2M byte (For OS and user screens)	
	A8GT-MCA4MFDW	Internal memory expansion 4M byte (For OS and user screens)	
Circuit monitor cassette	A8GT-MCAM	For circuit monitor functions	
SRAM memory card conforming to JEIDA Ver. 4.0 standard	MF3257-L5DAT01	SRAM made by Mitsubishi; memory capacity 256 KB	*1 Recommended product
	MF3513-L5DAT01	SRAM made by Mitsubishi; memory capacity 512 KB	
	MF31M1-L5DAT01	SRAM made by Mitsubishi; memory capacity 1 MB	
	MF32M1-L6DAT01	SRAM made by Mitsubishi; memory capacity 2 MB	
	MF3257-J1DAT01	SRAM made by Mitsubishi; memory capacity 256 KB; with backup battery	
	MF3513-J1DAT01	SRAM made by Mitsubishi; memory capacity 512 KB; with backup battery	
	MF31M1-J1DAT01	SRAM made by Mitsubishi; memory capacity 1 MB; with backup battery	
	MF32M1-J1DAT01	SRAM made by Mitsubishi; memory capacity 2 MB; with backup battery	
	Q1MEM-64S	SRAM for QnACPU; memory capacity 64 KB	
	Q1MEM-128S	SRAM for QnACPU; memory capacity 128 KB	
	Q1MEM-256S	SRAM for QnACPU; memory capacity 256 KB	
	Q1MEM-512S	SRAM for QnACPU; memory capacity 512 KB	
	Q1MEM-1MS	SRAM for QnACPU; memory capacity 1 MB	
	Q1MEM-2MS	SRAM for QnACPU; memory capacity 2 MB	
Bus connection in- terface module	A7GT-BUS	For bus connection (connector: large-sized CPU type connector)	
	A7GT-BUSS	For bus connection (connector: small-sized CPU type connector)	
Multidrop bus connec- tion interface module	A7GT-BUS2	For connecting to a multiple module bus (connector: large-sized CPU type connector)	
	A7GT-BUS2S	For connecting to a multiple module bus (connector: small-sized CPU type connector)	
Data link module	A7GT-J71AP23	For connection to MELSECNET (II) optical link; for local station only	
	A7GT-J71AR23	For connection to MELSECNET (II) coaxial link; for local station only	
	A7GT-J71AT23B	For connection to MELSECNET/B link; for local station only	

(continued from previous page)

Component	Model	Remarks
Network module	A7GT-J71LP23	For connection to MELSECNET/10 loop network; for ordinary station only
	A7GT-J71BR13	For connection to MELSECNET/10 coaxial bus network; for ordinary station only
Serial communications module	A8GT-RS4	For CPU direct connection; for calculator link connection; for connection to the PLC of other companies and for microcomputer connection.
External I/O interface module	A8GT-70KBF	For external I/O connection
Printer interface module	A8GT-70PRF	For printer connection
Printer connection cable	AC30PIO-20P	For connecting printer and printer interface module; cable length: 3 m (10 feet)
	AC300PIO-20P	For connecting printer and printer interface module; cable length: 30 m (98 feet)
RS-422 cable	AC30R4	For connecting GOT and PC CPU; cable length: 3 m (10 feet) For connecting GOT and serial communications module
	AC100R4	For connecting GOT and PC CPU; cable length: 10 m (33 feet) For connecting GOT and serial communications module
	AC300R4	For connecting GOT and PC CPU; cable length: 30 m (98 feet) For connecting GOT and serial communications module
Expansion cable	AC06B	Cable length 0.6 m (2 feet)
	AC12B	Cable length 1.2 m (4 feet)
	AC30B	Cable length 3 m (10 feet)
	AC50B	Cable length 5 m (16 feet)
	AC12B-R	Right-angle, cable length 1.2 m (4 feet)
	AC30B-R	Right-angle, cable length 3 m (10 feet)
	AC50B-R	Right-angle, cable length 5 m (16 feet)
	A1SC07B	Cable length 0.7 m (2.3 feet)
	A1SC12B	Cable length 1.2 m (4 feet)
	A1SC30B	Cable length 3 m (10 feet)
	A1SC60B	Cable length 6 m (20 feet)
	A1SC05NB	Cable length 0.5 m (1.6 feet)
	A1SC07NB	Cable length 0.7 m (2.3 feet)
	A1SC30NB	Cable length 3 m (10 feet)
	A1SC50NB	Cable length 5 m (16 feet)
	A8GT-C12NB	Cable length 1.2 m (4 feet)
	A8GT-C30NB	Cable length 3 m (10 feet)
	A8GT-C50NB	Cable length 5 m (16 feet)
Long-distance bus connection cable	A7GT-C100EXS	Cable length 10 m (33 feet)
	A7GT-C200EXS	Cable length 20 m (66 feet)
	A7GT-C300EXS	Cable length 30 m (100 feet)
	A8GT-C100EXSS	Cable length 10 m (33 feet)
	A8GT-C200EXSS	Cable length 20 m (66 feet)
	A8GT-C300EXSS	Cable length 30 m (100 feet)
Long-distance GOT connection cable	A7GT-C100B	Cable length 10 m (33 feet)
	A7GT-C200B	Cable length 20 m (66 feet)
	A7GT-C300B	Cable length 30 m (100 feet)
	A8GT-C100BS	Cable length 10 m (33 feet)
	A8GT-C200BS	Cable length 20 m (66 feet)
	A8GT-C300BS	Cable length 30 m (100 feet)

(continued from previous page)

Component	Model	Remarks
Bus connector conversion box	A7GT-C300B	For converting from the large connector to the small connector
Calculator link module connection cable	A7GT-AC30R4	For connecting GOT and calculator link module; cable length: 3 m (10 feet)
	A7GT-AC100R4	For connecting GOT and calculator link module; cable length: 10 m (33 feet)
	A7GT-AC300R4	For connecting GOT and calculator link module; cable length: 30 m (98 feet)
Fiber-optic cable	—	For connecting MELSECNET (II) optical link module or MELSECNET/10 optical loop network
Coaxial cable	—	For connecting MELSECNET (II) coaxial link module or MELSECNET/10 coaxial bus network
Twisted pair cable	—	For connecting MELSECNET/B

*1. Recommended product:

This product is guaranteed to have specifications (standards) that can be connected to our modules. These products should be used in conformance with the specifications (standards) of that product.

*2. Can be connected:

Products with this indication have specifications that allow connection to our modules. These products should be used in conformance with the specifications (standards) of that product.

*3. For differences between A7GT-BUS/BUS2 and A7GT-BUSS/BUS2S, refer to Section 12.7.

For information on component modules required for creating and transmitting project data, refer to Section 2.2.

4. Names of Parts and Their Settings

4.1 GOT Main Module

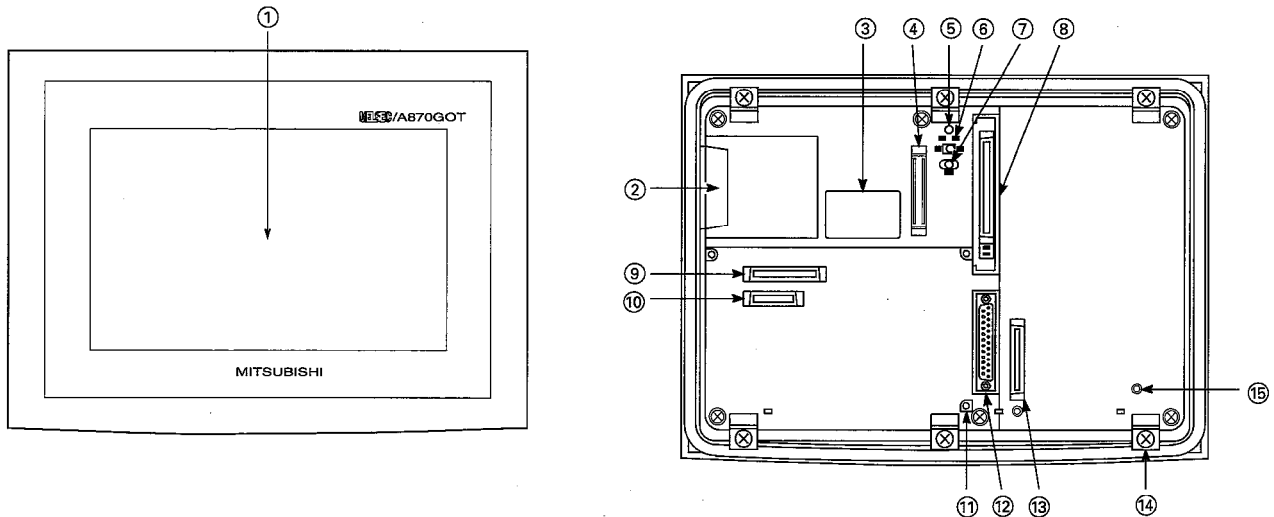

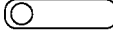
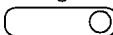
No.	Name	Contents	Remarks
①	Display module	Displays monitor screens	—
②	Memory card interface	Interface for installing the memory card	—
③	Ratings plate	—	—
④	Interface for connecting optional module	Interface for connecting optional module	—
⑤	Memory card LED	Indicates whether or not memory card can be installed. Not lighted — Memory card can be installed (when switch ⑥ is off) Lighted — Memory card cannot be installed (when switch ⑥ is on)	—
⑥	Memory card access switch	If memory card is installed while power is on, this specifies memory card access status. ON — Access from GOT to memory card is disabled. OFF — Access from GOT to memory card is enabled. (This is set to OFF when shipped from the factory.)	OFF setting  ON setting 
⑦	Reset switch	Resets the GOT hardware	With cassette cover
⑧	Memory cassette interface	Interface for connecting the memory cassette	—
⑨	Communications module interface 1	Interface for connecting a communications module	—
⑩	Communications module interface 1	Interface for connecting a communications module	—
⑪	Screw hole for attaching communications module	Screw hole for securing a communications module to the GOT	—
⑫	RS-232C interface	RS-232C interface for connecting a computer *1	—
⑬	Power supply module interface	RS-232C interface for connecting a power supply module	—
⑭	Fitting for attaching main module	When the attachment fitting is used to attach the GOT to a control panel or other component, the hook of the attachment fitting is inserted here to secure it.	—
⑮	Screw hole for attaching power supply module	Screw hole used to secure the power supply module to the GOT	—

*1 The connector used for the RS-232C interface that connects the computer should have a maximum thickness of 16 mm. (Suggested connector: 17JE-23250-02 (D8A6))
If the connector has a thickness that exceeds 16 mm, it will not fit the RS-232C interface.

4.2 Power Supply Module

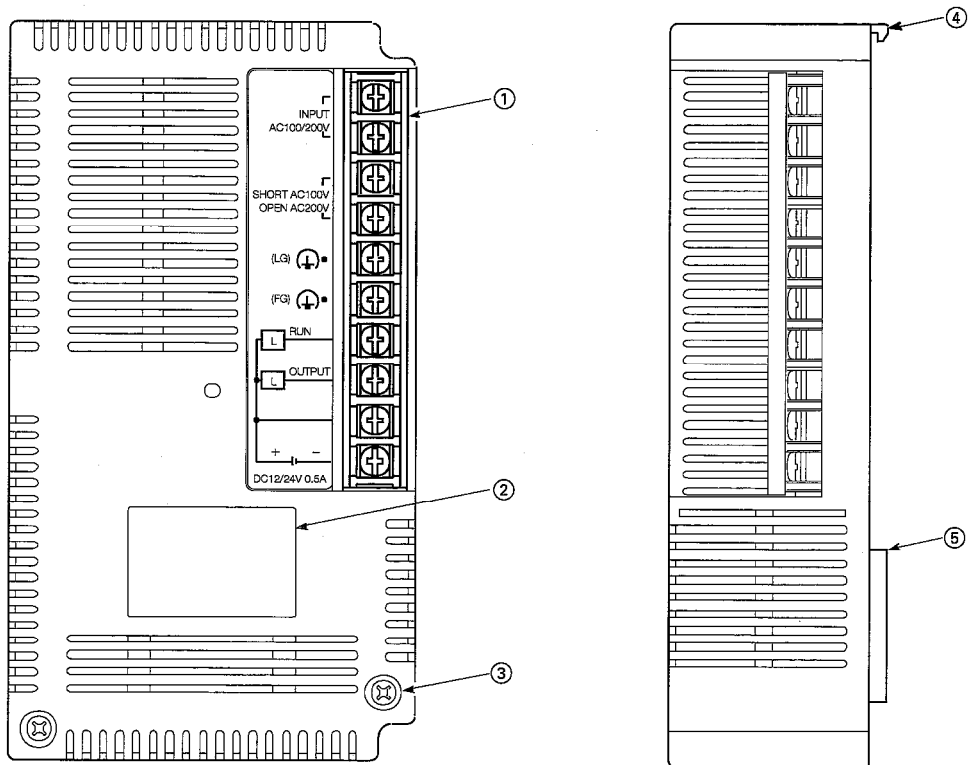

No.	Name	Contents	Remarks
①	Terminal base	<p>For 100/200 VAC power supply input and external output</p> <p>• When shorted: 100 VAC setting • When open: 200 VAC setting</p>	Use the short bar that comes with the product to set the 100 VAC setting.
②	Ratings plate	—	—
③	Power supply module attachment screw	Screw used to attach a power supply module to the GOT main module. The tightening torque range is 36 to 48 N·cm (3.7 to 4.9 kg·cm).	—
④	Power supply module securing hook	Hook used to secure the power supply module to the GOT main module	—
⑤	GOT main module connector	Connector used to connect the power supply interface of the GOT main module 13 (Cannot be used)	—

5. Handling Component Equipment Modules

5.1 Protective Sheets

5.1.1 Types of protective sheets

The A8GT-70PSCE, A8GGT-70PSCS, A8GT-70PSNE, and A8GT-70PSNS are protective sheets for the display module of the GOT.

Protective sheets are used for the following purposes:

- ① To protect the touch keys from scratches and dirt when using the touch key panel on the display module
- ② To prevent reflection from external disturbance light on the display module

The protective sheet used should be selected in accordance with the purpose for which it is used, from among those listed here.

Purpose	Model	Contents
Protection of display	A8GT-70PSCE	Transparent protective sheet (for EL); 5-sheet set
	A8GGT-70PSCS	Transparent protective sheet (for STN, TFT); 5-sheet set
Display module protection + anti-reflection	A8GT-70PSNE	Anti-reflection protective sheet (for EL); 5-sheet set
	A8GT-70PSNS	Anti-reflection protective sheet (for STN, TFT);5-sheet set

5.1.2 Attachment procedures

- ① Peel off the old protective sheet from the GOT display module.

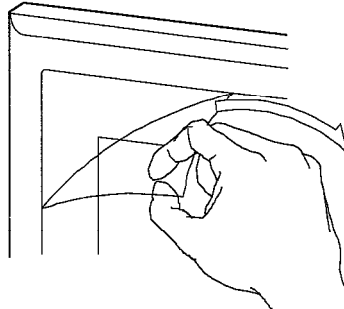

- ② Peel off the backing from the new protective sheet and affix the adhesive surface of the sheet to the display module of the GOT.

(Note) When affixing the protective sheet to the display module, make sure it is flat and tight, with no looseness or gaps at the adhesive sections.

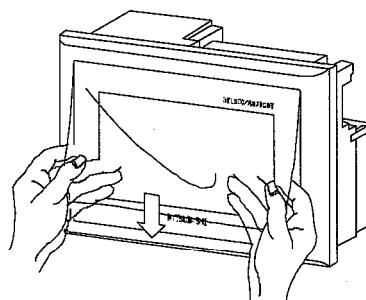

5.2 Memory Cassettes

5.2.1 Types of memory cassettes

Product	Model	Contents
Circuit monitor cassette	A8GT-MCAM	For circuit monitor functions
Expanded memory cassette	A8GT-MCA1MFDW	Internal memory expansion 1M byte + circuit monitor functions
	A8GT-MCA2MFDW	Internal memory expansion 2M byte + circuit monitor functions
	A8GT-MCA4MFDW	Internal memory expansion 4M byte + circuit monitor functions

5.2.2 Installing and removing memory cassettes

1 Installing the memory cassette

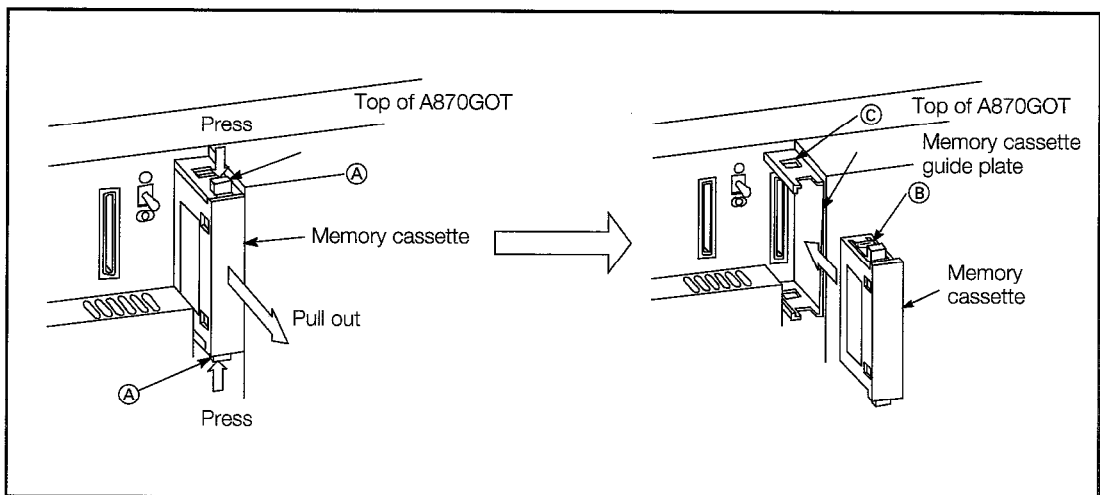

- ① Turn off the power supply to the GOT.
- ② Pressing with your first finger and thumb on the inner side of the projecting section of the memory cassette (marked A in the illustration), pull out the memory cassette.
- ③ Slide the memory cassette into position along the memory cassette guide plate, until the projecting section marked B comes in contact with the square hole marked B.

2 Precautions regarding handling

The following precautions should be observed when handling memory cassettes.

- ① The memory cassette is made of resinous materials, and should be protected from strong shock or impact.
- ② Do not separate the PCB of the memory cassette from the case, as this can result in a breakdown.
- ③ Be careful to keep foreign matter such as wire scraps out of the memory cassette. If foreign matter does get into the cassette, remove it right away.
- ④ When installing the memory cassette in the GOT, press it firmly against the connector.
- ⑤ Do not set the memory cassette on any metallic material which is or may be leaking electricity, or on any wood, plastic, vinyl, textile, or paper surface which may conduct static electricity.
- ⑥ Do not touch the leads of the memory cassette. This can cause the memory to be destroyed.
- ⑦ Do not touch the connector that connects the memory cassette to the GOT. Touching this connector can cause defective contact.

5.3 Memory Cards

5.3.1 Types of memory cards that can be used

Product	Model	Contents	Remarks
Memory card conforming to JEIDA Ver. 4.0 standard	MF3257-L5DAT01	SRAM made by Mitsubishi; memory capacity 256 KB	Recommended product
	MF3513-L5DAT01	SRAM made by Mitsubishi; memory capacity 512 KB	
	MF31M1-L5DAT01	SRAM made by Mitsubishi; memory capacity 1 MB	
	MF32M1-L6DAT01	SRAM made by Mitsubishi; memory capacity 2 MB	
	MF3257-J1DAT01	SRAM made by Mitsubishi; memory capacity 256 KB; with backup battery	
	MF3513-J1DAT01	SRAM made by Mitsubishi; memory capacity 512 KB; with backup battery	
	MF31M1-J1DAT01	SRAM made by Mitsubishi; memory capacity 1 MB; with backup battery	
	MF32M1-J1DAT01	SRAM made by Mitsubishi; memory capacity 2 MB; with backup battery	
	Q1AMEM-64S	SRAM for QnACPU; memory capacity 64 KB	
	Q1MEM-128S	SRAM for QnACPU; memory capacity 128 KB	
	Q1MEM-256S	SRAM for QnACPU; memory capacity 256 KB	
	Q1MEM-512S	SRAM for QnACPU; memory capacity 512 KB	
Q1MEM-1MS	SRAM for QnACPU; memory capacity 1 MB		
Q1MEM-2MS	SRAM for QnACPU; memory capacity 2 MB		

5.3.2 Installing and removing the memory card

Memory cards can be installed and removed with the power supply on, but the procedure outlined below should be carried out first to enable installation and removal of the card.

1 Preparation for installing/removing memory card with power on

Turn off the memory card access switch on the GOT, and make sure the memory card LED has gone out.

Once the memory card LED has gone out, the memory card can be installed and removed even if the power supply is on.

2 Installing the memory card

Install the memory card in the GOT with the front surface facing up.

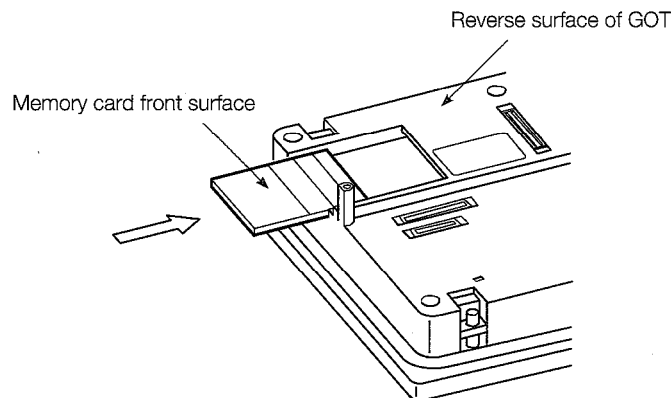

3 Removing the memory card

Turn off the memory card access switch on the GOT, and make sure the memory card LED has gone out. Then remove the card.

Removing the card while the memory card LED is lighted can destroy the contents of the card.

5.3.3 When and how to replace the battery

1 Checking for a drop in battery power

The GOT can check the memory card battery to see if the power has dropped. (This can be done only when the memory card access switch is on.)

The battery power is checked in the following ways:

- ① The battery power is checked during the self-test function (see Section 7.8).
If the battery power is low, a message will be displayed on the self-test screen.
- ② The battery power is also checked by the alarm list display (system alarm) function.
If the battery power is low, an error warning message and the "Battery Low" error code will be displayed on the monitor screen.

For more information on the monitor functions in steps ②, please refer to the A8GOTP Operating Manual (Monitor Screen Creation Manual).

2 Battery lifetime

For the backup time period of a memory card that conforms to JEIDA Ver. 4.0 standards, please refer to the instruction sheet that comes with the memory card.

3 Replacing the battery

Please refer to the instruction sheet that comes with the memory card.

5.4 Installing the Communications Modules

This section explains how to install the various communications modules in the GOT.

5.4.1 Installing the serial communications module

This shows how to install a serial communications module in the GOT. For more detailed information on installing a serial communications module and entering the settings, please refer to the A8GT-RS4 User's Manual.



DANGER

- Before installing a serial communications module in the GOT, or removing a module already installed, switch all phases of the external power supply off to the GOT.

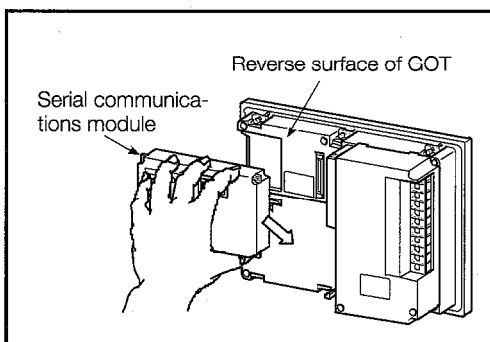

- ① Install the serial communication module to the GOT, then fix it in place by tightening the screws of the serial communication module within the range of specified torque, 39 to 59 N·cm (4 to 6 kg·cm).

To remove the serial communications module, loosen the screw, and then reverse the installation procedure.

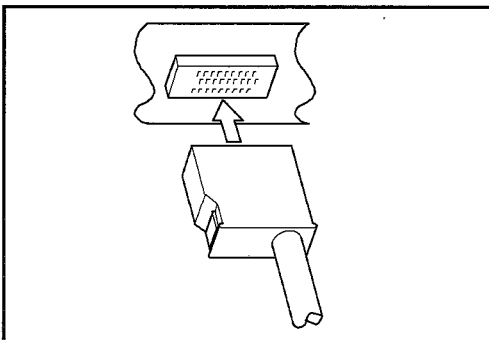

- ② Connect the serial communications module and the PC CPU/calculator link module using the RS-422 cable.

5.4.2 Installing the bus connection module

This shows how to install a bus connection module in the GOT. For more detailed information on installing a bus connection module and entering the settings, please refer to the A7GT-BUS/A7GT-BUS 2 User's Manual.



DANGER

- Before installing a bus connection module in the GOT, or removing a module already installed, switch all phases of the external power supply off to the GOT.

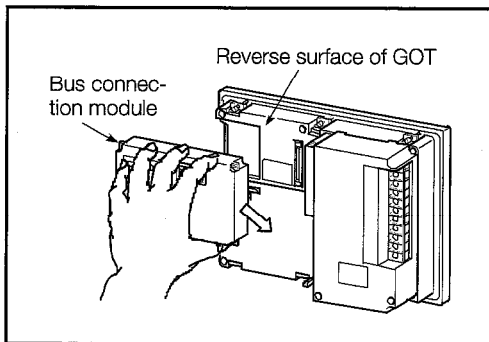

- ① Install the bus connection module to the GOT, then fix it in place by tightening the screws of the bus connection module within the range of specified torque, 39 to 59 N·cm (4 to 6 kg·cm).

To remove the bus connection module, loosen the screw, and then reverse the installation procedure.

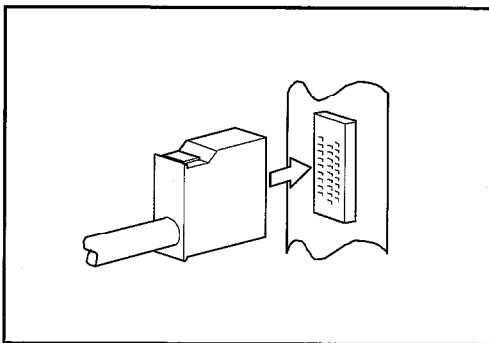

- ② Connect the bus connection module and the main base/expansion base module using the expansion cable.

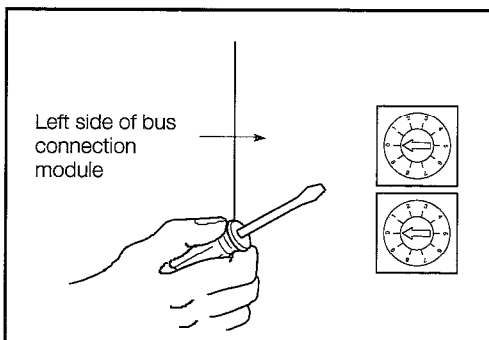

- ③ Set the expansion stage switch and I/O slot switch of the bus connection module.

After setting these switches, turn on the power supplies to the PC CPU and the GOT.

This completes the procedure for entering settings for the bus connection module.

Refer to Section 13.2 for instructions regarding the setting method for the bus connection module's expansion stage switch and I/O slot switch.

5.4.3 Installing a data link module

This shows how to install a data link module in the GOT. For more detailed information on data link module specifications and settings, please refer to the A7GT-J71AP23/R23 User's Manual, the A7GT-J71AT23B User's Manual, and the MELSECNET and MELSECNET/B Data Link System Reference Manuals.



DANGER ● Before installing a data link module in the GOT, or removing a module already installed, switch all phases of the external power supply off to the GOT.

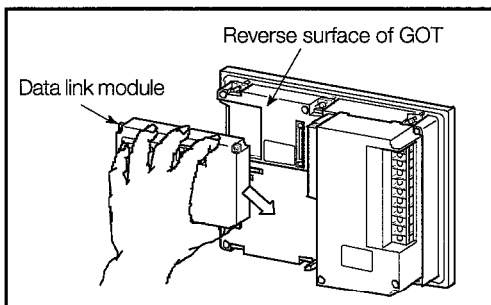

- ① Install the data link module to the GOT, then fix it in place by tightening the screws of the data link module within the range of specified torque, 39 to 59 N·cm (4 to 6 kg·cm).
To remove the data link module, loosen the screw, and then reverse the installation procedure.

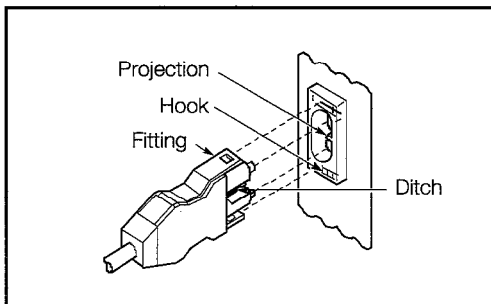

- ② Connect the link cable to the data link module. For instructions on connecting a coaxial cable or twisted pair cable, please refer to the MELSECNET and MELSECNET/B Data Link System Reference Manuals.

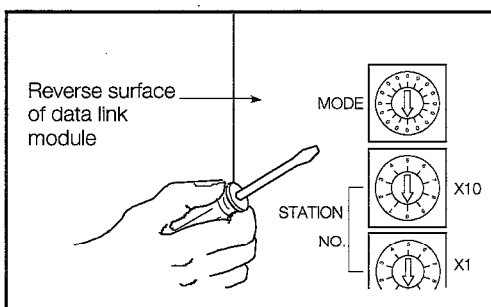

- ③ Set the mode change switch of the data link module to the Test Mode.

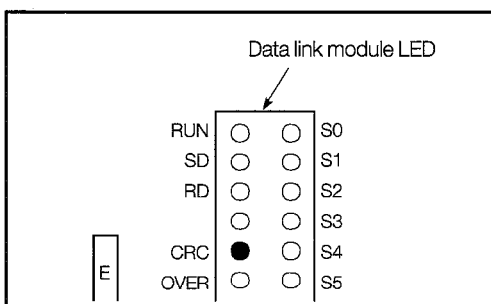

- ④ Turn on the power supply to the GOT and run a test of the data link.

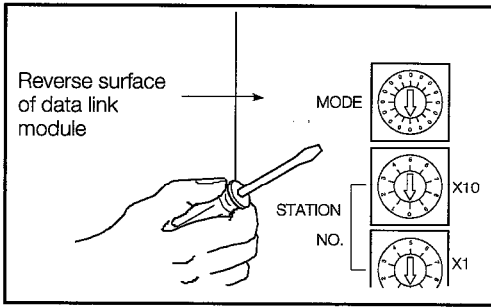

- ⑤ After the test has been completed, turn off the power supply to the GOT, and set the various switches on the data link module to match the system configuration.
This completes the procedure for setting the data link module.

1 Setting the switches on the data link module

This section explains how to set the switches used with the data link module.

(a) Station number setting switch

Since this data link module acts only as a local station, it should be set as follows:

- MNET (II): Stations 1 to 64
- MNET/B: Stations 1 to 31

(b) Mode change setting switch

Set this to the on-line mode for a data link.

(c) Baud rate switch (MNET/B only)

Set this to the baud rate set for the master station.

2 Precautions when using a data link module

The data link module acts only as a local station, so the station number setting switch should be set to "0".

3 Testing the data link connection (self-test)

The self-test checks elements such as the data link hardware and link cable connections. This test can be selected by setting the mode change setting switch to the third item shown below.

Switch setting	Name	Contents
5	Inter-station test mode (main station)	This mode checks the circuits between two stations. The station with the lower number serves as the main station, and the other as the sub station.
6	Inter-station test mode (sub station)	
7	Self-test	This checks the hardware, including sending and reception circuits in the transmission system, based on the data link module as a stand-alone module.

Let's look at how the self-test is carried out.

The self-test checks the hardware of the data link module, including sending and reception circuits (main loops and auxiliary loops) in the transmission system, based on the data link unit as a stand-alone module. For other testing methods, please refer to the MELSECNET and MELSECNET/B Data Link System Reference Manuals.

The self-test procedure is described below.

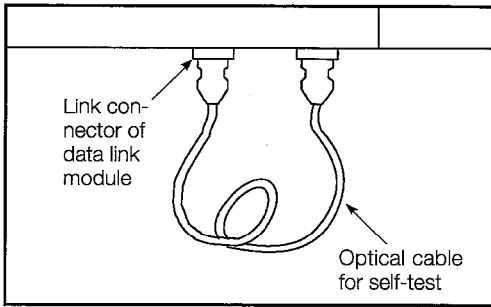

- ① Turn off the power supply to the GOT, and connect the link cable between the link connectors of the data link module, in a folded-back connection. For instructions on connecting a coaxial cable, please refer to the MELSECNET and MELSECNET/B Data Link System Reference Manuals. A twisted-pair cable does not need to be connected.

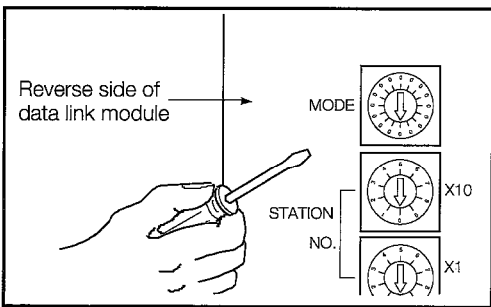

- ② Set the mode change setting switch on the data link module to "7" (this is the self-test setting).

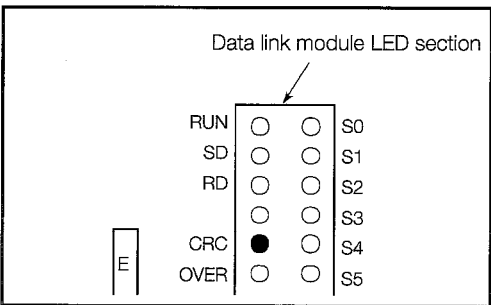

- ③ Turn on the power supply to the GOT and start the self-test. The test status and results are shown in the display section of the data link module LED.

(Judging the test results)

- Normal — The following flash in sequence: "CRC", "OVER", "AB.IF", "TIME", "DATA", "UNDER".
- Error — One of the above LEDs lights, and the test stops. The following should be checked as possible causes of the error:
 - A cable may be disconnected.
 - The transmission side and receiving side have not been connected with a cable.
 - The transmission side of the main loop is connected to the transmission side of the auxiliary loop, and the receiving side of the main loop is connected to the receiving side of the auxiliary loop.
 - There is a problem with the hardware of the data link module.

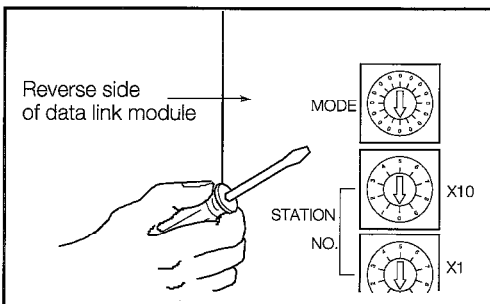

- ④ If the results of the test are normal, the test procedure is concluded. Set the mode change setting switch of the data link module to "0" or "1", and turn on the power supply to the GOT (this sets the on-line mode).

5.4.4 Installing a network module

This shows how to install a network module in the GOT. For more detailed information on network module specifications and settings, please refer to the A7GT-J71LP23/BR13 User's Manual and the MELSECNET/10 Network System Reference Manual (For PC Networks).

! DANGER ● Before installing a network module in the GOT, or removing a module already installed, switch all phases of the external power supply off to the GOT.

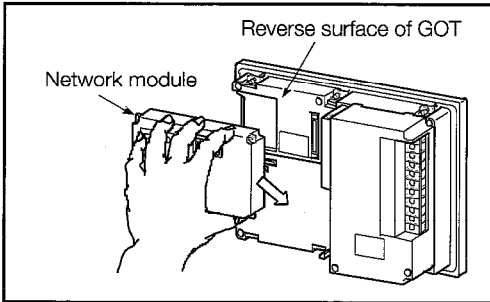

- ① Install the network module to the GOT, then fix it in place by tightening the screws of the network module within the range of specified torque, 39 to 59 N·cm (4 to 6 kg·cm). To remove the network module, loosen the screw, and then reverse the installation procedure.

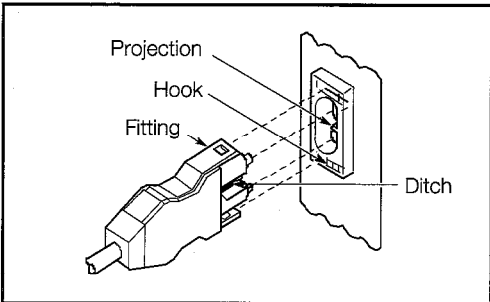

- ② Connect the link cable to the network module. For instructions on connecting a coaxial cable, please refer to the MELSECNET/10 Network System Reference Manual (For PC Networks).

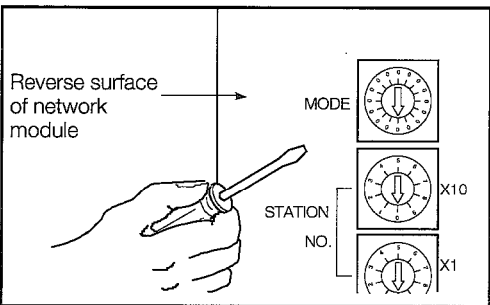

- ③ Set the mode change switch of the network module to the Test Mode.

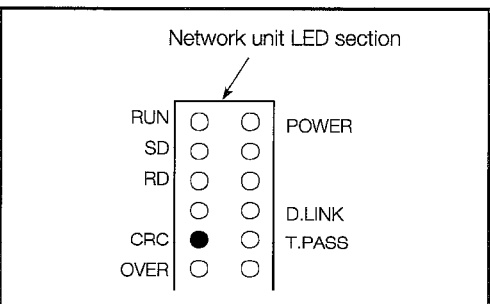

- ④ Turn on the power supply to the GOT and run a link test of the network.

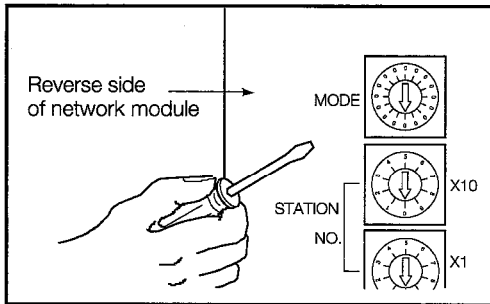

- ⑤ After the test has been completed, turn off the power supply to the GOT, and set the various switches on the network module to match the system configuration.

This completes the procedure for setting the network module.

1 Setting the switches on the network module

This section explains how to set the switches used with the network module.

- (a) Network number setting switch

Set the number of the network connected to the network module.

- (b) Group number setting switch

Set the number of the group to be incorporated into the network module. If no group is to be specified, set "0" for this.

- (c) Station number setting switch

The network module should be set as follows, depending on whether an optical loop system or a coaxial bus system is used.

- Optical loop system (A7GT-J71LP23): Stations 1 to 64
- Coaxial bus system (A7GT-J71BR13): Stations 1 to 32

- (d) Mode change setting switch

Set this to the on-line mode when using a network.

2 Precautions when using a network module

The network module acts only as an ordinary station, so the control station shift function cannot be used. Also, the range of other stations with which communications can be exchanged is limited to those stations of network connected to the network module. Communications cannot be exchanged with other stations on other networks.

3 Testing the network connection (self-test)

The self-test checks elements such as the network hardware and cable connections. This test can be selected by setting the mode change setting switch to the tenth item shown next page.

Switch setting	Name	Contents
3	Loop test (main loop)	This mode checks the circuits after all of the stations have been connected. It sets all of the stations other than those being checked in the on-line mode and then runs the test (only with optical loop systems).
4	Loop test (auxiliary loop)	
5	Inter-station test mode (main station)	This mode checks the circuits between two stations. The station with the lower number serves as the main station, and the other as the sub station.
6	Inter-station test mode (sub station)	
7	Self-test	This checks the hardware, including sending and reception circuits and cables in the transmission system, based on the network unit as a stand-alone module.
8	Internal self-test	This checks the hardware, including sending and reception circuits in the transmission system, based on the network module as a stand-alone module.
9	Hardware test	This checks hardware inside the network module.
D	Network no. check	This checks the network number, group number, and station numbers specified for the network module.
E	Group no. check	
F	Station no. check	

Let's look at how the self-test is carried out.

The self-test checks the hardware of the network module, including sending and reception circuits (main loops and auxiliary loops) and cables in the transmission system, based on the network module as a stand-alone module.

For other testing methods, please refer to the MELSECNET/10 Network System Reference Manual (For PC Networks).

The self-test procedure is described below.

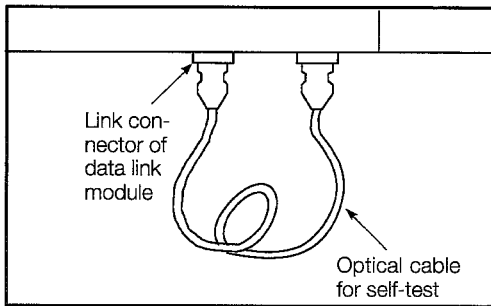

- ① Turn off the power supply to the GOT, and connect the optical cable between the connectors of the network module, in a folded-back connection.

For instructions on connecting a coaxial cable, please refer to the MELSECNET/10 Network System Reference Manual (For PC Networks).

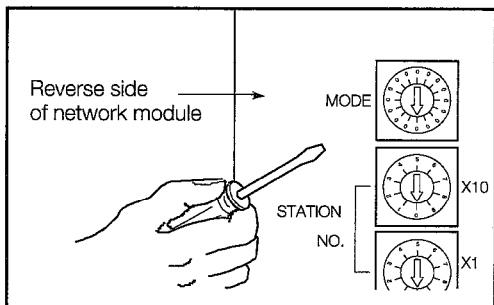

- ② Set the mode change setting switch on the network module to "7" (this is the self-test setting).

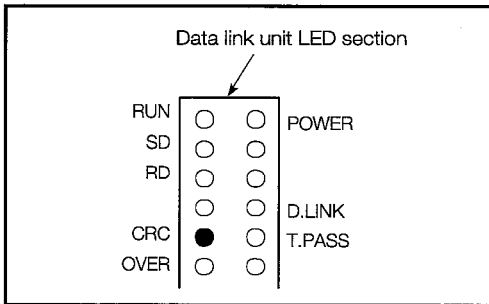

- ③ Turn on the power supply to the GOT and start the self-test. The test status and results are shown in the display section of the network module LED.

(Judging the test results)

- Normal — The following flash in sequence: “CRC”, “OVER”, “AB.IF”, “TIME”, “DATA”, “UNDER”.
- Error — One of the above LEDs lights, and the test stops. The following should be checked as possible causes of the error:
 - A cable may be disconnected.
 - The transmission side and receiving side have not been connected with a cable.
 - The transmission side of the main loop is connected to the transmission side of the auxiliary loop, and the receiving side of the main loop is connected to the receiving side of the auxiliary loop.
 - There is a problem with the hardware of the network module.

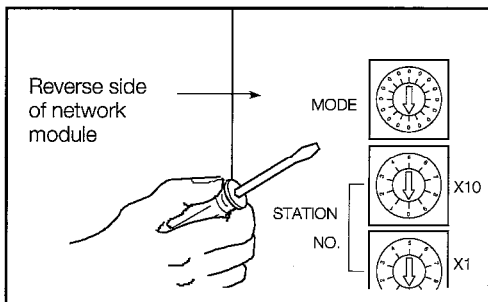

- ④ If the results of the test are normal, the test procedure is concluded. Set the mode change setting switch of the network module to “0”, and turn on the power supply to the GOT (this sets the on-line mode).

5.5 Installing a Power Supply Module

This section shows how to enter the settings for the power supply module installed in the GOT.



DANGER

- When installing a power supply module in the GOT, or removing it from the GOT, switch all phases of the external power supply off to the GOT and PC. Not doing so could result in electric shock, damage to the module or malfunctioning.



CAUTION

- When wiring the power supply module, always check the rated voltage of the product first, as well as the terminal layout, and make sure wiring is done correctly. Connecting a power supply of the wrong voltage or wiring the module erroneously could result in fire or breakdowns.

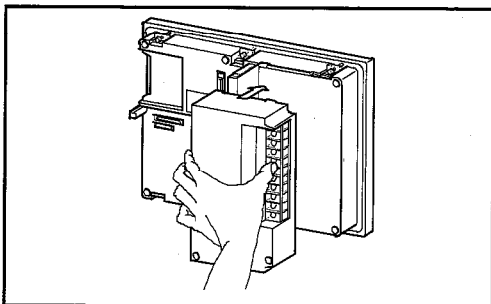

- ① Install the power supply module to the GOT, then fix it in place by tightening the screws of the power supply module within the range of specified torque, 39 to 59 N·cm (4 to 6 kg·cm). To remove the power supply module, loosen the screw, and then reverse the installation procedure.

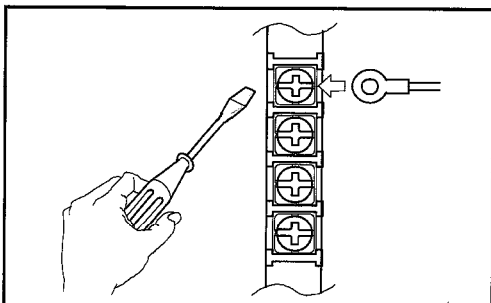

- ② Connect the power supply module to the terminal base with the power supply cable. If the power supply voltage is 100 VAC, set (short) 100 VAC on the short side of the power supply terminal. Connect the power cables grounded to the FG and LG terminals. If external output is being used, connect the output terminal and the equipment being used with power cables. After completing the wiring, cover it with a protective cover to make sure no one touches it.

5.6 Installing a Printer Interface Module/External I/O Interface Module

This section shows how to enter the settings for the printer interface module/external I/O interface module installed in the GOT. For more detailed information on printer interface module/external I/O interface module specifications, please refer to the A8GT-70PRF User's Manual and the A8GT-70KBF User's Manual.



DANGER

- When installing a printer interface module/external I/O interface module in the GOT, or removing it from the GOT, switch all phases of the external power supply off to the GOT and PC.

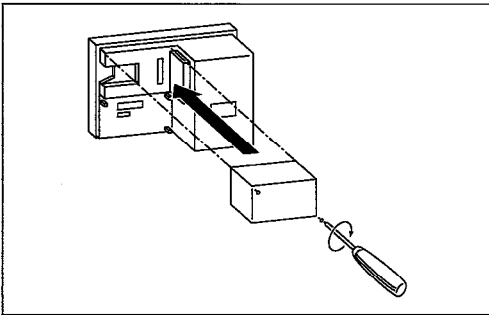

- ① Insert connectors A8GT-70PRF and A8GT-70KBF in the interface for connecting module atop GOT.
- ② Firmly fix it in place by tightening the module fixed screws within the range of specified torque, 39 to 59 N·cm (4 to 6 kg·cm).

To remove the module, loosen the screw, and then reverse the installation procedure.

6. Procedures to Prepare for Starting Operation

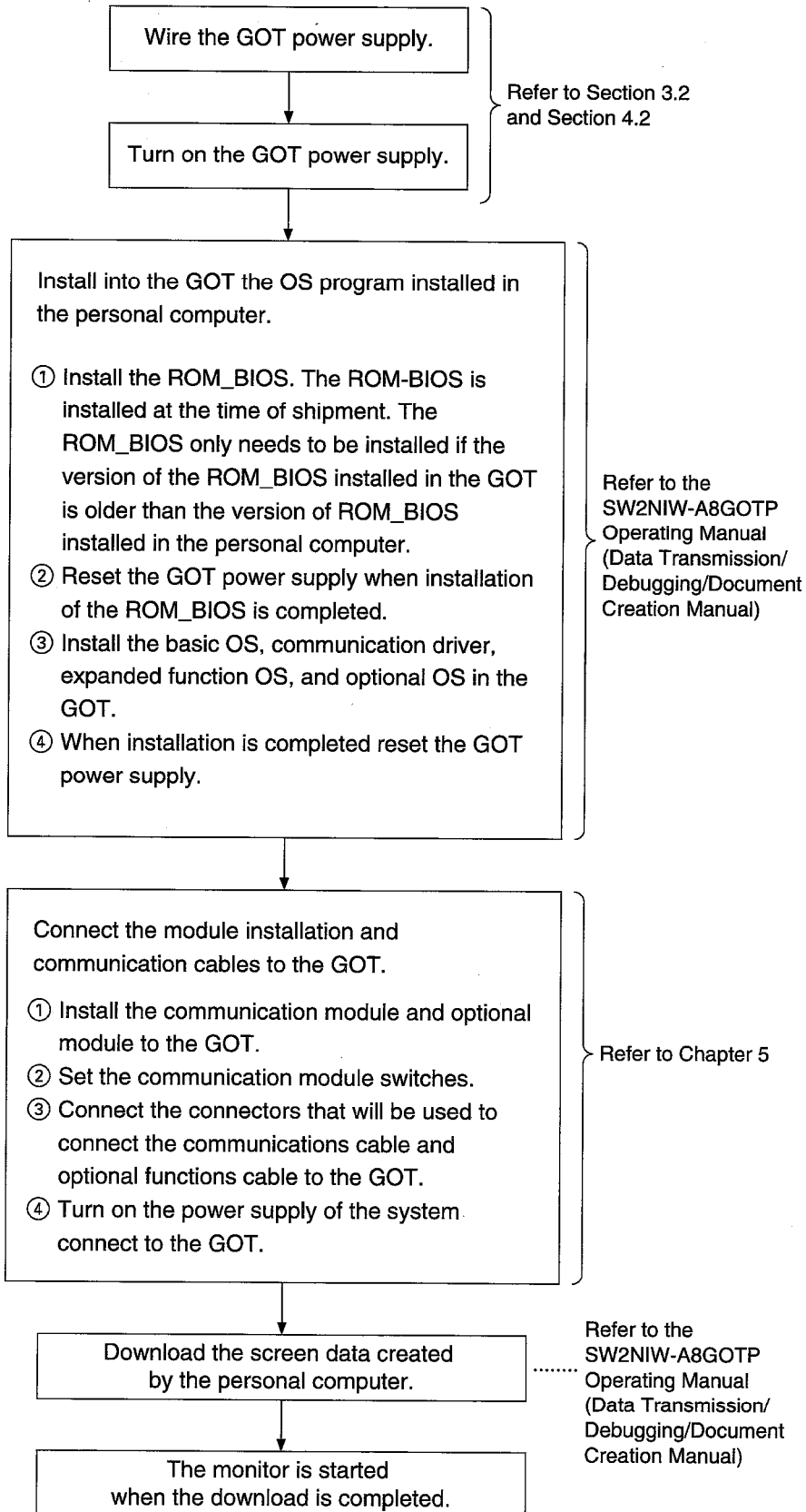

7. Operating Utility Functions

7.1 Table of Utility Functions

Item	Contents	Remarks	Ref. Page
Brightness adjustment Message display selection	Adjusts the backlight brightness Selects the screen message display (Japanese/English)		Section 7.3
System monitor	Monitors/changes CPU devices	Can only be executed when OS is installed from graphics software to GOT	Section 7.4
Special module monitor	Monitors/changes special function unit buffer memory	Can only be executed when OS is installed from graphics software to GOT	Section 7.5
Screen copy	Transmits data between internal memory of screen data and memory card	Only screen data created by the user	Section 7.6
Setup	Sets the following items: <ul style="list-style-type: none"> • Message display selection (Japanese/English) • Buzzer sound adjustment • Screen saver time setting 		Section 7.7
Self-test	Tests the following hardware modules of the GOT: <ul style="list-style-type: none"> • Drawing check • Font check • Memory card check • Check of user area in internal memory • Check of OS area of internal memory • CPU communications check • Check of touch keys 		Section 7.8
Memory information	Displays the following information: <ul style="list-style-type: none"> • OS version • Format of communications with PC CPU • Space available in internal memory • Whether or not memory card is inserted, and available space • Whether or not circuit monitor function exists 		Section 7.9
Circuit monitor	Monitors sequence programs of PC CPU	Can only be executed when memory card is installed and OS is installed from graphics software to GOT	Section 7.10
Clock function	Sets date/time of PC CPU		Section 7.11
Screen cleaning	Displays screen in order to clean display module		Section 7.12
File function	The following information of the data stored by the alarm history function is display, data deletion, data capacity, and storage date and time. <ul style="list-style-type: none"> • Memory card format 		Section 7.13

7.2 Procedures to Prepare for Running the Various Functions

This section outlines the various procedures used to prepare for running the utility functions. All of the utility functions can be operated using the touch keys on the monitor screen.

There are two ways to start up the utility functions, as described below.

- (1) Touch the top right and top left corners of the monitor screen at the same time.

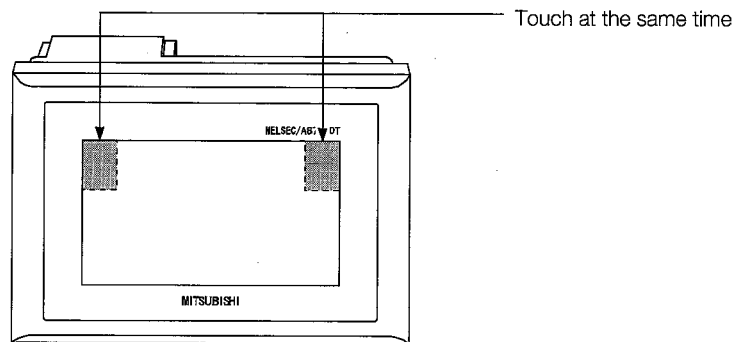

- (2) On the monitor screen, specify the touch key (expansion) function, and input the settings using the touch keys. (For information on entering settings using touch keys, please refer to the A8GOTP Operating Manual (Monitor Screen Creation Manual).)

The following shows an outline of the utility function procedures.

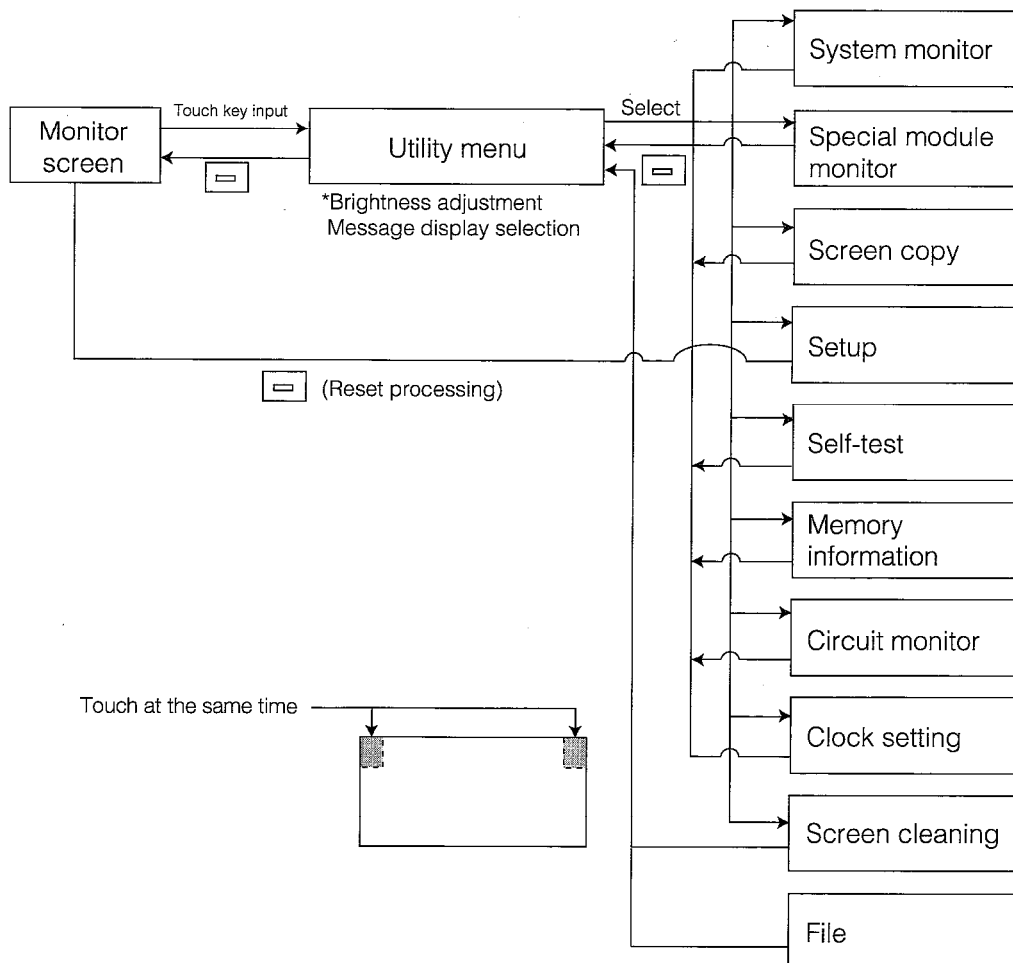

7.3 Selecting Functions on the Utility Menu Screen

(Adjusting the Screen Brightness — Brightness Adjustment)

(Selecting the Screen Message Display — Message Display Selection)



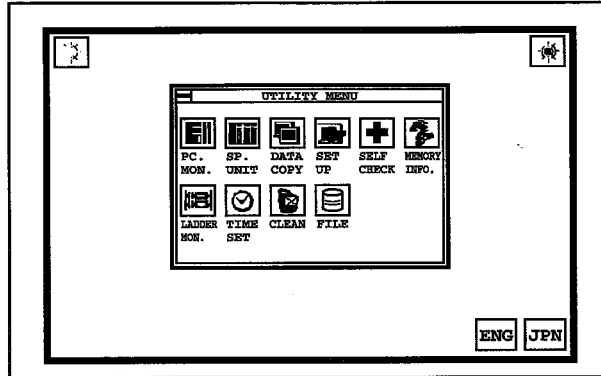



1 Display screen



2 Functions

- This is the menu screen where the various utility functions are selected.
- The brightness of the screen can be adjusted on this screen.
- The screen message display (Japanese/English) can be selected on this screen.

3 Operation

- Basic operation
 - Directly touch the section where the function to be selected is displayed.
- Return to the monitor screen
 - Touching the  returns to the monitor screen.
- Brightness adjustment
 - Touch  .
 - The brightness can be adjusted in 50 steps.
The brightness adjustment is the STN type only.
- Message display selection
 - Touch  or . (: English, : Japanese)

Point

- If the OS has not been installed in the GOT, the items for system monitoring and special module monitoring are displayed, but cannot be selected.
- If no memory cassette has been installed in the GOT, or if the OS has not been installed in the GOT, the items for circuit monitoring are displayed, but cannot be selected.
- If the PC CPU connected to the GOT does not have a clock function, the clock setting is displayed, but cannot be selected.

4 Error messages displayed in response to operations

Message	Cause	Corrective Action
Can't be selected (When system monitor, special module monitor, circuit monitor, or clock setting is selected)	<ul style="list-style-type: none"> • OS has not been installed in GOT • Memory card has not been in • PC CPU connected to GOT has no clock function 	<ul style="list-style-type: none"> • Install the OS. • Install the memory cassette. • Replace the PC CPU with one that has a clock function, or do not use the clock function.

7.4 Monitoring PC CPU Device Data on a Dedicated Screen (System Monitor)

Point

In order to use the system monitor function, the OS must be installed from the graphics software to the GOT.

1 Display screen

Example of screen

ENTRY MONITOR MENU FORM SET				BATCH MONITOR MENU FORM SET			
NETWK No.[0] STATION[FF]				NETWK No.[0] STATION[FF]			
D	15	-2147483648	DW	D	10	32767	
D	10	-32767		D	11	0	D 19 3234
X	001	●		D	12	0	D 20 0
M	25	○		D	13	-1	D 21 0
Y	70	●		D	14	0	D 22 0
W	200	43		D	15	3	D 23 -32768
R	50	68378428	DW	D	16	0	D 24 0
D	0	3		D	17	0	D 25 0

TC MONITOR MENU FORM SET				BM MONITOR MENU FORM SET			
NETWK No.[0] STATION[FF]				NETWK No.[0] STATION[FF] I/O NO[-1]			
T	0	PV	0 SV	0	↑	○	▲
				BM 1110	-32768	BM 1118	0
				BM 1111	64	BM 1119	0
T	1	PV	0 SV	0	↑	○	
				BM 1112	149	BM 1120	150
				BM 1113	-1111	BM 1121	131
T	2	PV	150 SV	150	■	●	
				BM 1114	126	BM 1122	-32768
				BM 1115	160	BM 1123	555
T	3	PV	0 SV	0	↑	○	
				BM 1116	255	BM 1124	2368
				BM 1117	1200	BM 1125	11000

2 Functions

- Bit devices and word devices of the PC CPU can be monitored and changes made.
- Contact points, coils, set values, and current values for the PC CPU timer and counter can be monitored and changes made.
- The contents of the special function module buffer memory can be monitored and changes made.

3 Operation

(a) Basic operation

- Operations can be carried out by touching the monitor screen directly.
- For detailed information, please refer to the A870GOT Graphic Operation Terminal Operating Manual (Expanded Functions Manual).

(b) Returning to the utility menu screen

- Touching the  returns to the monitor screen.

7.5 Monitoring the Special Functions Module Buffer Memory on a Dedicated Screen (Special Functions Module Monitor)

Point

The following operations must be carried out in order to use the special module monitoring function.

- ① Install the OS from the graphics software to the GOT.
- ② Download the special module monitor data from the graphics software to the GOT.

1 Display screen

Example of screen

		SET/ RESET	Data Chg.	MONIT MENU	END
X	Y			X	AB0DDBRF
X00	Y11	Posit. Start	Travel/Pulse		
	Y12	Interpolation	Indching Trav.	Y	AB0DDBRF
X02	X03	Posit. Comp.	Speed Limit		
X06	X07	Zeno Request	Jog Speed Limit		
Y13	Y14	Zeno Start	Acc/Dec Time		
X08	X09	Zeno Complete	Backlash Comp		
Y17	Y19	Rad. Jog Start	Upper Limit		
Y18	Y1A	Rev. Jog Start	Lower Limit		
Y1E	Y16	Stop	Error Comp.		
X0E	X0F	Pos. Started	Starting Bias		
X04	X05	BUSY	Comp. JOP Time		
X0E	X0F	M Code ON			
X00	WDT Err	Man. Pulse			
X0A	Batt. Err	X:W1			
X0B	Error	Y:W1			

2 Functions

- The contents of the buffer memory of the special functions module can be monitored and changes made.
- Input and output signals of the special function module can be monitored and changes made on dedicated screens.

3 Operation

- (a) Basic operation
 - Operations can be carried out by touching the monitor screen directly.
 - For detailed information, please refer to the A870GOT Graphic Operation Terminal Operating Manual (Expanded Functions Manual).
- (b) Returning to the utility menu screen
 - Touching the  returns to the monitor screen.

7.6 Copying Monitor Data Between the Internal Memory and Memory Card (Screen Copy)

When the alarm history function data is stored in the memory card that uses this function the screen data copied using the screen copy function is deleted. Use separate memory cards of the memory cards for the screen copy function and the alarm history function.

1 Display screen

Example of screen

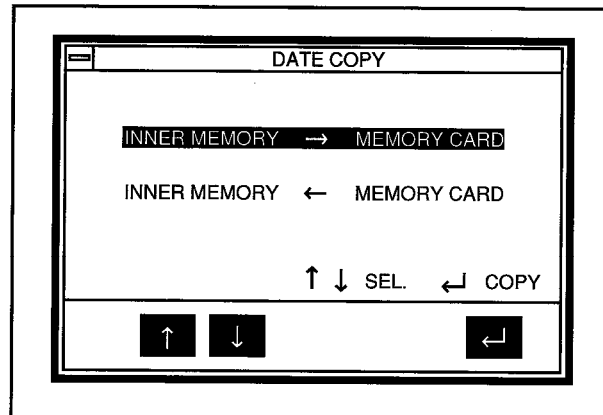

2 Functions

- Project data can be backed up from the internal memory to a memory card.
- Project data backed up from the memory card to the internal memory can be copied.

3 Operations

(a) Basic operations

- Items are selected by touching the and keys.
- Touching the key displays the message "OK to execute?".
- To execute the function, touch the key once again. To select an item, use the and keys. To interrupt a function, touch the key. However, please be aware that this returns to the utility menu screen.

(b) Returning to the utility menu screen

- Touching the returns to the utility menu screen.

4 Error messages displayed in response to operations

Message	Cause	Corrective Action
Cancel write protect function	The write protect function has been specified on the memory card.	Cancel the write protect function on the memory card.
Install memory card	No memory card has been installed in the GOT.	Install a memory card in the GOT.
Format memory card	The memory card installed in the GOT has not been formatted.	Format the memory card. (See Section 8.4.)
Insufficient memory on card	The amount of space available on the memory card which has been installed is less than the contents of the internal memory.	Replace the memory card with one which has sufficient space available.
Memory card error	There is a hardware problem with the memory card which has been installed.	Replace the memory card.

7.7 Entering GOT Usage Environment Settings (Setup)

Point

Executing the setup function and touching  automatically resets the GOT and displays the monitor screen.

1 Display screen

Example of screen

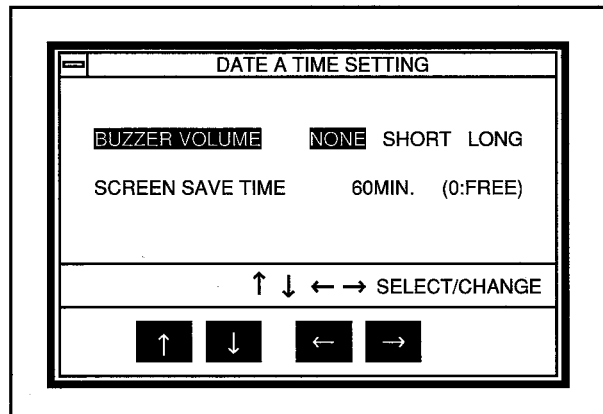













* The Settings and selected items are highlighted.

2 Functions

- The screen message display (Japanese/English) can be selected. (When shipped from the factory, this is set to Japanese.)
- The length of the buzzer can be selected. (When shipped from the factory, this is set to “Short”.)
- The timing of the screen saver function can be set.
 - Screen saver function —
 - In order to keep the display module from burning out, this function turns off the display if it is not touched within a specified period of time. (The backlight does not go off.)
 - If the display has been turned off, it can be turned on again simply by touching it.
 - If this timing is set to “0”, the screen is always displayed.

3 Operations

(a) Basic operations

- Items are selected by touching the  and  keys.
- Settings are changed by pressing the  and  keys.
- The setting for the screen saver timing can be changed by touching the  and  keys to highlight the digits, and then the  and  keys to set the numeric value. (If another item is selected right after this setting is entered, touching the  key returns the highlighted display to the “Screen Saver Time” parameter, where the  and  keys can be used for selection.)
- After entering a setting, touch the  key.

When the  key is pressed, the GOT is reset automatically, and the monitor screen is displayed.

7.8 Self-Test of the GOT Main Module Hardware (Self-Test)

1 Display screen

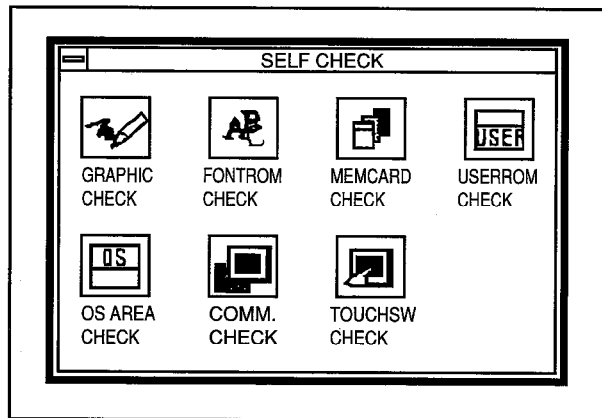

2 Functions

This tests the hardware modules of the GOT listed below.

- Drawing check — Checks visually for sections of the display module where colors or display elements are missing.
- Font check — Checks visually for distortion in the character font.
- Memory card check — Checks the memory card hardware.
- Internal memory user area check — Checks the user area of the internal memory.
- Internal memory OS area check — Checks the OS area of the internal memory.
- CPU communications check — Checks the status of communications between the GOT and the PC CPU. (This requires a program in the PC CPU. Also, if the MELSECNET is connected, the link parameters are required as well.)
- Touch keys check— Checks the touch keys.

These are checked by the GOT.

3 Operations

(a) Basic operations

- Touch the display section of the item to be run.
- To operate the various items, follow the messages displayed on the screen.
- When an item has been completed without errors, a message is displayed, indicating that no problems occurred.
- If a problem is detected, an error message is displayed, stating the content of the error.
- The following three types of screens are drawn during the drawing check:
 - ① The entire screen is displayed in one color. The colors used for display change in the order of: blue → red → purple → green → blue/green → yellow → white.
 - ② Basic graphics such as circles and squares are displayed.
 - ③ Ovals and checked patterns are displayed either alternately, or in a superimposed display.
- To check CPU communications, the following program and link parameters should be written to the PC CPU. (Link parameters are necessary only if a MELSECNET is connected.)

* Program

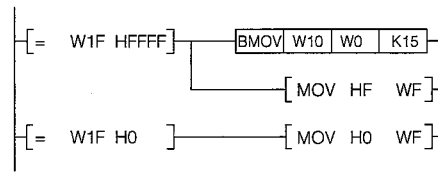

* Link parameters

- Station M (CPU) → Station L (GOT):
W0 to F
- Station M (CPU) → Station L (GOT):
W10 to 1F
- Settings for B/X/Y are not necessary.

(b) Returning to the utility menu screen

- Touching the  returns to the utility menu screen.

7.9 Displaying Various Types of GOT System Information (System Information)

1 Display screen

Example of screen

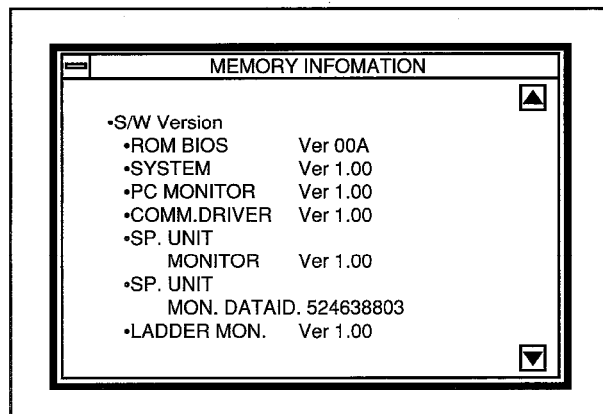



2 Functions

This displays the various types of memory information for the GOT shown below.

- OS version
- Format for communications with the PC CPU
- Available space in internal memory
- Whether or not memory card is installed, and amount of space available on memory card
- Whether or not circuit monitor function exists

3 Operations

(a) Basic operations

The screen can be scrolled by touching the  and  keys.

(b) Returning to the utility menu screen

- Touching the  returns to the utility menu screen.

7.10 Monitoring the Circuits of the PC CPU Sequence Program (Circuit Monitor)

Point

The following operations are necessary for circuit monitoring.

- ① Install the memory card in the GOT.
- ② Install the OS from the graphics software to the GOT.

1 Display screen

Example of screen

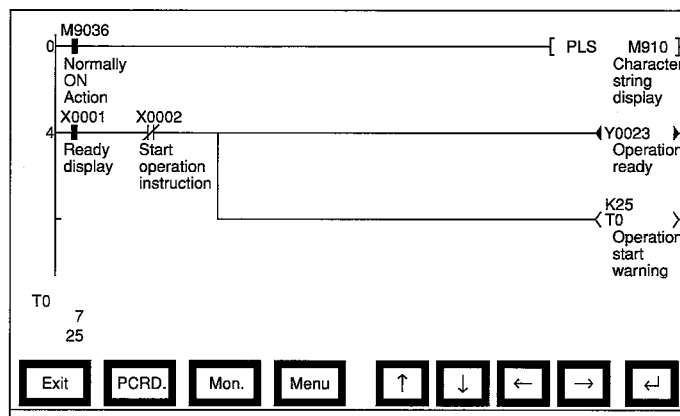

2 Functions

- Sequence programs of the PC CPU can be monitored.
- Other stations on the network system can be monitored (within the same network only).
- Monitoring can be switched between the main and sub programs.

3 Operations

(a) Basic operations

- Operations are carried out by touching the monitor screen.
- For detailed information, please refer to the A870GOT Graphic Operation Terminal Operating Manual (Expanded Functions Manual).

(b) Returning to the utility menu screen

- Touching the  returns to the monitor screen.

7.11 Specifying the PC CPU Clock Data (Clock Setting)

1 Display screen

Example of screen

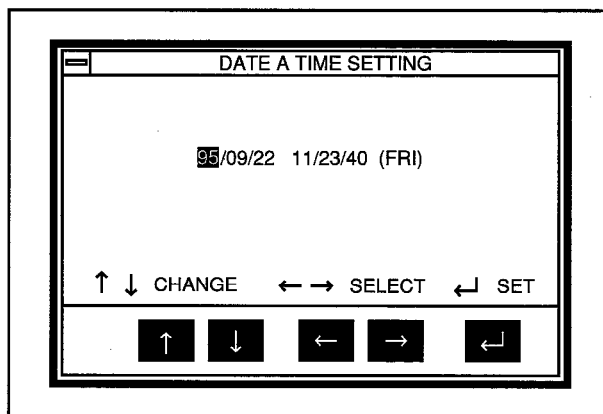

* The date and time displayed in the setting window are those shown when the clock setting screen is displayed. The time most recently set is always shown at the upper right of the screen. After you have finished entering the settings, check this time at the upper right of the display.

2 Functions

- On the clock controlled by the PC CPU, the date, time, and day can be set.

3 Operations

(a) Basic operations

- Items are selected by touching the and keys.
- Numeric values are changed by touching the and keys.
- Touching the key sets the clock data in the PC CPU.

(b) Returning to the utility menu screen

- Touching the returns to the monitor screen.

Point

- The clock setting should be entered when the system is booted.
- When using a sequence program or similar program on the PC CPU side to read and write clock data, settings for the clock data cannot be entered properly using this function.
- If the PC CPU connected to the GOT does not have a clock function, this function cannot be selected on the Utility menu.

7.12 Displaying the Display Section Cleaning Screen (Screen Cleaning)

1 Display screen

Example of screen

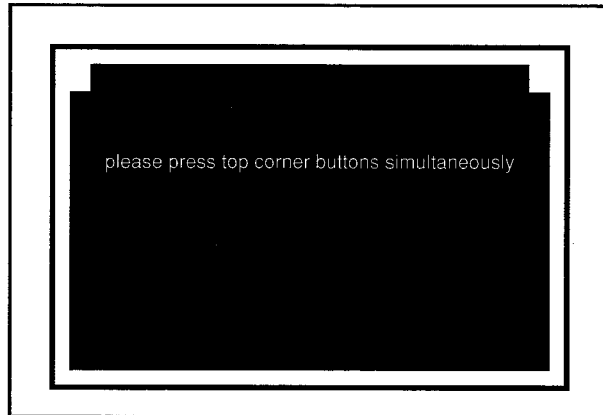

2 Functions

- When cleaning the display module, displaying a completely black screen makes the surface easier to see.

3 Operations

(a) Basic operations

- Touching the upper right and left corners of the screen simultaneously returns to the Utility menu.

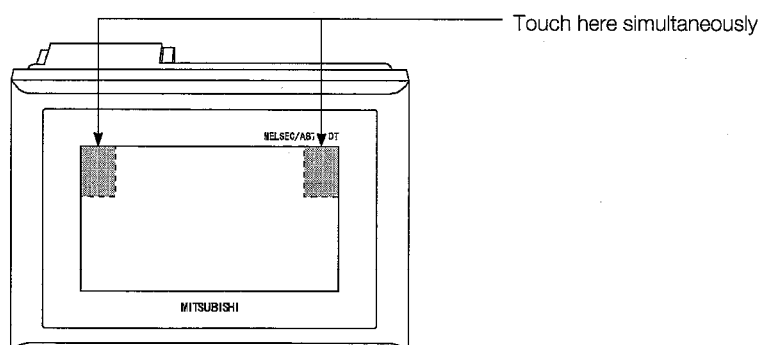

7.13 Checking Data Information Stored by the Alarm History Function

The same memory card cannot be used for the alarm history function and the screen copy function. If the alarm history function data is stored in the memory card in which the screen copy function screen data is stored the data stored by the screen copy will be deleted, so take due precautions.

Use separate memory cards for the memory cards for the screen copy function and the alarm history function.

If a different memory card (several memory cards for alarm history can be used) is switched in while this screen is displayed, the data information of this switched in memory card cannot be displayed. Redisplay this screen from the utility screen.

1 Display screen

The screenshot shows a screen titled "FILE MAINTENANCE". At the top left, it says "FILE NAME". Below this, a data entry shows "ALARMHST.DAT 100 97/04/30 12:30:10". To the right of this entry are two arrow buttons (up and down) and two buttons labeled "DELETE" and "ALL DELETE". Below the data entry is a large empty rectangular box. At the bottom right, there are two buttons labeled "FORMAT" and "END". At the very bottom of the screen, it displays "AVAILABLE CAPACITY 1048476 BYTES CAPACITY 1048576 BYTES FILE 1".

2 Function

- The file name, capacity, date, and time of the data stored by the alarm history function can be checked. (The file name of the data stored by the alarm history function is set to the above ALARMHST.DAT. fixed)
- The memory card can be formatted.
- The data stored by the alarm history function can be deleted.

3 Operation

- (a) Operation for deleting the data stored by the alarm history function

Touch the to select the data to be deleted.

After making the selection touch the .

To delete all of the data stored in the memory card touch .

- (b) Operation for formatting the memory card

Touch .

- (c) To return to the utility menu

Touch to return to the utility menu.

8. Off-line Functions

All off-line functions are processed from the graphics software in relation to the GOT.

Point

There are no operations on the GOT side.

For detailed information on operation with the graphics software, please refer to the A8GOTP Operating Manual (Data Transmission/Debugging/Document Creation Manual).

8.1 Table of Off-line Functions

Item	Contents	Remarks
Install	Installs the OS from the computer to the internal memory of the GOT.	
Download	Downloads project data and special module monitor data from the computer to the internal memory of the GOT.	
Upload	Uploads project data from the internal memory of the GOT to the computer.	
Memory card format	Formats the memory card installed in the GOT.	
Memory information	Sends the following information to the computer: the version of the OS currently installed in the GOT, the space available in the internal memory, and the space available on the memory card.	This can also be checked using "Memory Information" under the GOT utility functions (see Section 7.9).

9. Installation

9.1 Precautions Regarding Handling

This section explains precautions which should be observed when handling the GOT.



DANGER

- Before beginning any installation or wiring work, make sure all phases of the power supply have been obstructed from the outside. Failing to completely shut out the power supply phases could cause electrical shock and/or damage to the product.
- Following installation or wiring work, when turning on the power supply and operating the equipment, make sure the terminal cover provided as an accessory has been attached to the product. Failing to attach the cover could result in electrical shock.



CAUTION

- Be careful never to let foreign matter such as filings or wiring scraps get inside the module. These can cause fire, breakdowns, and malfunctioning.
- Communications cables should not be bundled with main circuits and power lines, or installed in the vicinity of these.
- The communications cable should be connected securely to the connector on the communications module, and checked after being installed, to make sure it is not loose. Defective contact could cause malfunctioning.
- Make sure the memory cassette is installed securely in its connector. After connecting the connector, check to make sure it is securely tightened and not loose. Defective contact could cause malfunctioning.
- The FG and LG terminals should always be grounded using the Class 3 ground designed especially for the Graphic Operation Terminal, or a higher class of ground. Failing to ground these terminals sufficiently could cause electrical shock and/or malfunctioning.
- Before wiring the GOT, check the rated voltage and terminal layout of the wiring, and make sure wiring is done correctly. Connecting a power supply that differs from the rated voltage, or wiring it incorrectly, could cause fire and/or breakdowns.
- Tighten terminal screws to the rated torque.
Failing to tighten terminal screws adequately could cause short-circuits, fire, and/or malfunctioning.

- The module is made of resinous materials, and should be protected from strong shock or impact.
- Do not separate the PCB of the module from the case, as this can result in a breakdown.
- When attaching the main module to the control panel, position the display module as shown below.
 - If the temperature inside the panel is 55°C, the display module should be attached at an angle within the range of 60 to 105°.

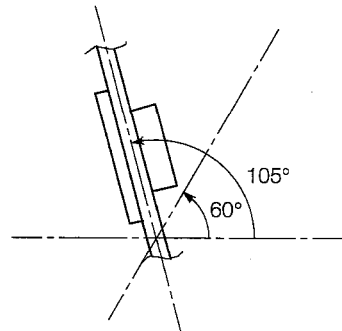
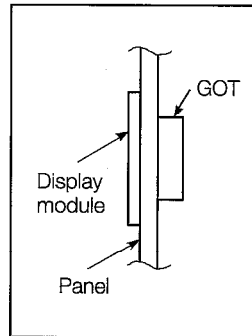

- Using the display module at an angle outside the range noted above may cause the GOT to wear out faster than it would otherwise. Make sure the temperature inside the panel does not exceed 40°C.

9.2 Installation Environment

CAUTION

When installing the equipment, make sure the location satisfies the general specifications, and avoid locations like those listed below. Using the equipment in an environment outside the range of the general specifications could result in electrical shock, fire, malfunctioning, and damage to or deterioration of the product.

- Locations where the temperature changes drastically and condensation occurs
- Locations where the equipment is exposed to direct sunlight
- Locations where strong electrical or magnetic fields are generated
- Locations where the main module is exposed to direct vibration or impact

9.3 Attachment Procedures

Use the fittings that come with the main module to assemble it.

1 Attachment panel and processing dimensions

If modules such as the control panel door and an attachment base made by the user are to be attached, the door and attachment base need to be processed as shown in the illustration below.

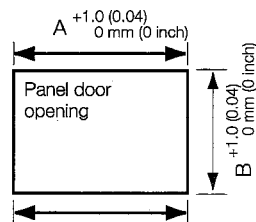

Unit: mm (inch)

Model	A	B
A8GT-70GOT-SW	301 (11.9)	203 (8.0)
A8GT-70GOT-SB		
A8GT-70GOT-TW		
A8GT-70GOT-TB		
A8GT-70GOT-EW	266 (10.5)	183 (7.2)
A8GT-70GOT-EB		

2 Attachment position

When attaching the GOT, it should be separated from other equipment by the clearances indicated below.

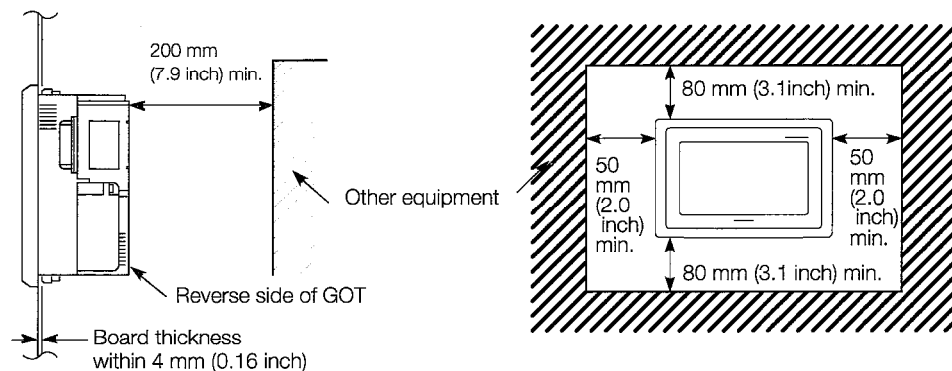

3 Attachment procedure

- (a) Insert the front of the main module first.
- (b) The module is attached at six places on the top and bottom of the GOT, as shown below.

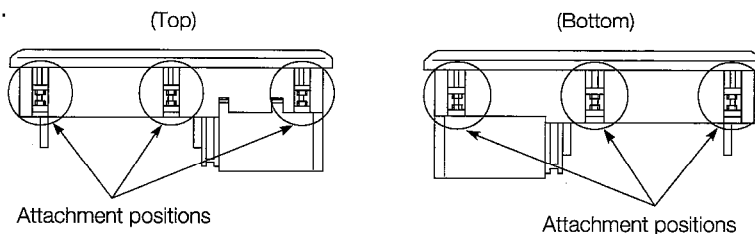

- (c) Attach the attachment fittings as shown below.

The tightening torque should be in the range of 62 to 83.5 N-cm (7 to 8 kg-cm).

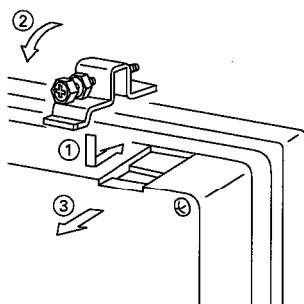

Slip in the fastener in the direction shown in ① and then fasten the fastener in the order of ② then ③, and then fasten the panel with screws.

10. Maintenance and Inspection

In order to make sure your PC is kept operating in optimum condition, certain items should be inspected daily, and others on a regular basis. These items are described below.

10.1 Daily Inspection

The items noted in Table 10.1 should be inspected daily.

Table 10.1 Daily Inspection

Item	Item to Inspect	Inspection Method	Judgment Criteria	Corrective action
1	Module attachment conditions	Check for loose attachment screws and covers that are not tightly attached.	Make sure they are firmly attached.	Tighten screws securely.
2	Connections	Loose terminal screws	There should be no loose screws.	Tighten terminal screws securely.
		Proximity to crimping terminals	There should be appropriate spacing.	Space appropriately.
		Connector area of cables	There should be no loose connectors.	Tighten connector fixed screws securely.

10.2 Periodic Inspection

The items noted below should be inspected once or twice every six months. If the equipment is moved or renovated, or if wiring is changed, these items should be inspected at that time.

Table 10.2 Periodic Inspection

Item	Item to Inspect	Item Method	Judgment Criteria	Corrective action	
1	Ambient environment	Measure with thermometer/barometer. Measure corrosive gases.	Display area	0 to 40°C	If used inside the panel, in-panel temperature should be same as ambient temperature
			Other parts	0 to 55°C	
			10 to 90% RH		
			No corrosive gases		
2	Power supply voltage check	Measure voltage between 24 VAC terminals.	15.6 to 31.2 VPC	Change power supply	
3	Attachment conditions	Looseness, rattling	Try moving the module.	Should be attached firmly and securely	Tighten screws
		Dirt or foreign matter	Check visually.	Should not be any adhering to equipment	Remove/clean
4	Connections	Loose terminal screws	Tighten with a screwdriver.	No loose screws	Tighten
		Proximity to crimping terminals	Check visually.	Appropriate spacing	Correct spacing
		Loose connectors	Check visually.	No loose connectors	Tighten connector screws

10.3 Precautions during Maintenance and Inspection

The following precautions should be observed when carrying out maintenance and inspections.



DANGER

- Do not touch the terminals while the power is on. Doing so may cause electric shock or malfunctioning.
- Switch all phases of the external power supply off before cleaning or re-tightening terminal screws.
Not doing so could result in electric shock.



CAUTION

- Never disassemble or modify the module. This could cause fire, breakdowns, and/or malfunctioning.
- Switch all phases of the external power supply off before attaching or detaching component modules. Doing this while conductivity is being supplied could cause a module to break down, or could cause malfunctioning.
- When disposing of this product, treat it as industrial waste.

10.4 Replacing the LCD Backlights

The STN/TFT type has two backlights built into the LCD of the display module. As time goes by, these backlights gradually become dimmer. When the display module screen becomes hard to see, the backlights should be replaced.



DANGER

- When replacing the backlight, turn off the GOT power, and first remove the GOT main module from the panel. If left in the panel, the GOT could fall and cause an injury. If this is done while the power is on it could cause electric shock.



CAUTION

- Do not touch the GOT's circuit board or electronic components when replacing the backlight. Doing so could cause trouble or malfunction.
- Be sure to take the following precautions when replacing the TFT backlight (A8GT-70LTT).
 - Wear gloves or finger socks when replacing the backlight.
 - Replace the backlight after waiting 5 or more minutes after turning the GOT's power off. The heat from the backlight can cause burns.
- When disposing the backlight, treat it as industrial waste.

Use the procedure below to replace the backlights.

- (1) Loosen the GOT attachment fittings, and remove the GOT from the base.
- (2) ① Using a screwdriver, remove the six securing screws from the back of the GOT.
② When the screws have been removed, remove the case of the control circuit section from the case of the display module.

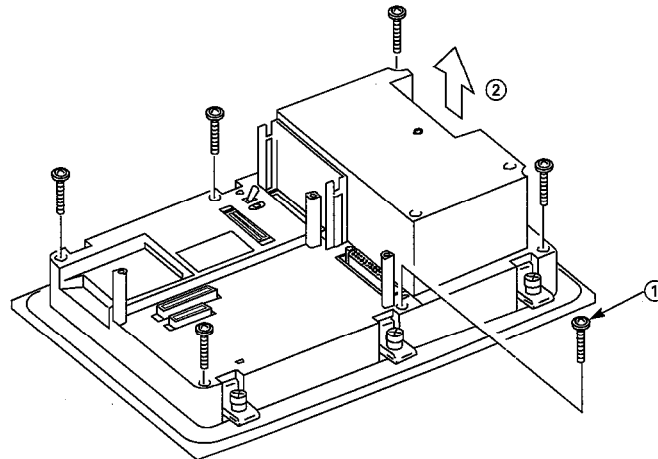

- (3) ① Remove the six screws securing the display module in place.
② When the screws have been removed, remove the display module from the case.

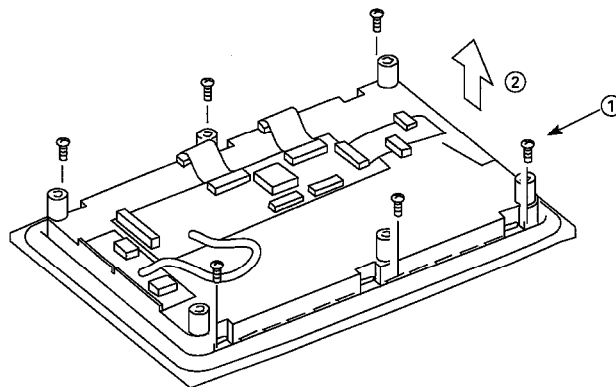

- (4) ① Turn over the display module, and disconnect the backlight cable connectors from the display module connectors (in two places).
For the SNT type remove from two locations on the top and bottom of the display module, and for the TFT type remove from one location on the top of the display module.
- ② Take the two backlights off of the display module.
For the SNT type remove two backlights from the top and bottom of the display module, and for the TFT type remove one backlight from the top of the display module.

· STN-type

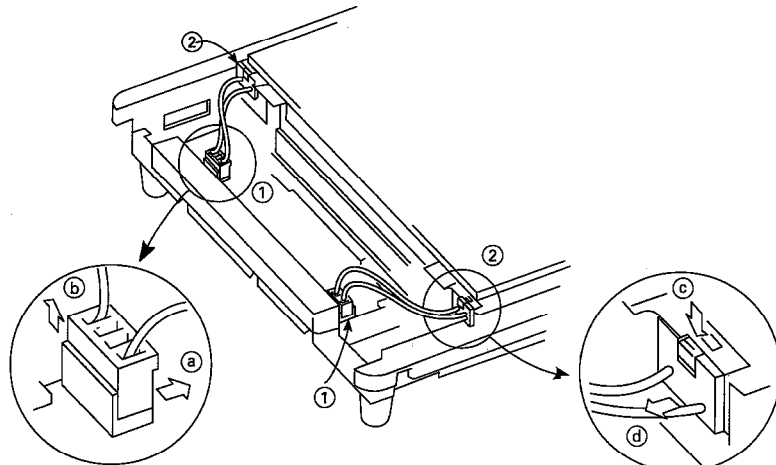

Holding the connector, tip it slightly toward the (a) side, and pull it upwards, in direction (b).

Pressing on the backlight fitting at (c) with a finger, pull it in direction (d).

· TFT-type

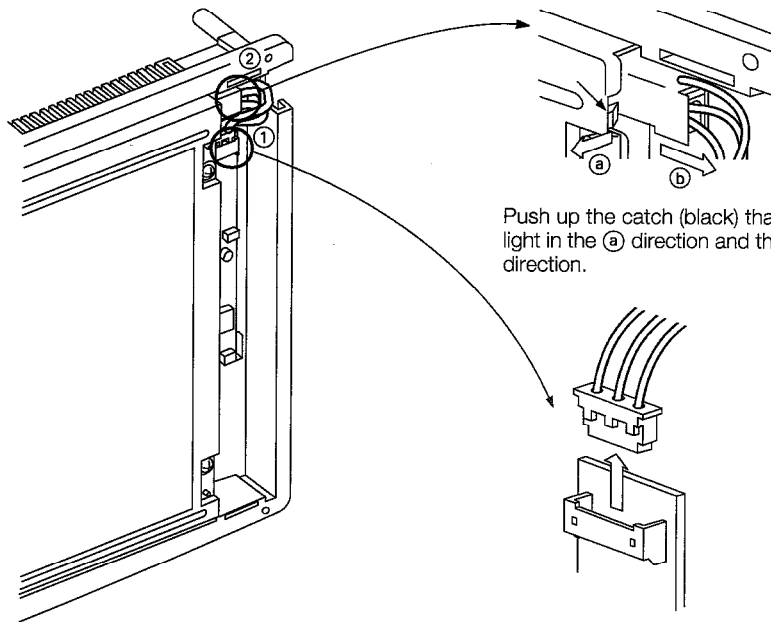

Push up the catch (black) that is holding the backlight in the (a) direction and then pull it out in the (b) direction.

Remove the backlight cable connector from the display unit connector.

- (5) Install the new backlights by reversing the above procedure, and fit the display module back into its case.

Point

Securing screws should be tightened to a tightening torque of 39 to 59 N·cm (4 to 6 kg·cm).

11. Error Codes and Error Messages

This section explains the error codes and error messages displayed in the alarm list display of the monitor function.

11.1 Interpreting the Display Contents

This section explains how to look at the error codes and error messages displayed on the monitor screen, and to decipher the correct response and the reference page.

First, let's look at error codes for the system which are displayed on the monitor screen from the alarm list display of the monitor function.

1 Display format on monitor screen Displayed at position specified by user

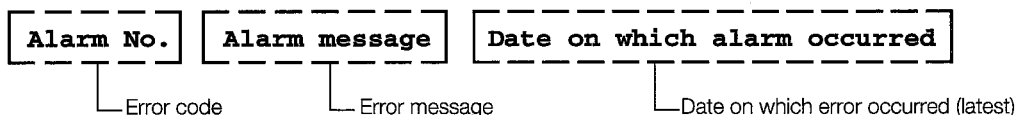

2 Error codes and reference manuals

Location where error occurred	Error code	Reference
ACPU	0 to 199 (D9008 value)	User's manual for the ACPUs connected to the GOT
MNET/B, MNET (II)	200 to 299	MNET (II), MNET/B Data Link System Reference Manual (see page with instructions on special relays for links) *1
GOT	300 to 499	Section 11.2
MNET/10	500 to 799	MNET/10 Network System Reference Manual (see page with instructions on special relays for links) *2
QnACPU	1000 to 9999 (SDO value)	User's manual for the QnACPU connected to the GOT

*1. See the page which explains the special relays for the link of the (error code) + 9000, and take the appropriate steps to correct the problem. For example, if error code (210) is displayed, this would be 210 + 9000 = 9210, so the error would be corrected as described by M9210.

*2. See the page which explains the special relays for the link of the (error code) - 500, and take the appropriate steps to correct the problem. For example, if error code (510) is displayed, this would be 510 - 500 = 10, so the error would be corrected as described by SB000A. (Special relays for links use hexadecimal format, so hexadecimal values should be substituted for decimal values.)

11.2 Tables of Error Codes and Error Messages

1 Error messages displayed before monitoring

Error message	Error contents	Corrective action
Check communication circuit. (cable, driver, module)	Cable, installed communications driver, or communications module is faulty	Check for loose cables and mounting status of communications module. Also check the installed communications driver.
Check memory data.	Arrangement of each installed OS program version is improper.	Check each installed OS program version.

2 Error code and error message during monitoring

Error codes and error messages detected by GOT are shown below.

The error code can be checked with the system information function of the error code storage area and with the alarm list (system alarm) function.

For information on the system information function and the alarm list function, refer to the SW2NIW-A8GOTP Operating Manual (Monitor Screen Creation Manual).

Error code	Error message	Error contents	Remedy
303	Number of specified monitoring points is excessive.	System work area cannot be secured because sprite settings of the screen to be shown are excessive.	Reduce the number of sprite setting points.
304	Number of specified trigger points is excessive.		
305	Number of specified printout points is excessive.		
306	No monitor data	Screen data is not downloaded to built-in memory.	Download screen data to built-in memory.
310	Specified monitor data does not exist or is outside range.	(1) Specified base screen/window screen does not exist in project data. (2) Specified base screen/window screen is outside permissible range (1 to 1024)	(1) Specify base screen/window screen that exists. (2) Specify base screen/window screen of 1 to 1024 that exists.
320	Specified parts do not exist or are outside range.	Part No. set in parts display does not exist.	Check specified parts numbers of screen data parts display.
321	Specified station number of monitor device is incorrect.	Specified station number of applicable monitor does not exist or is not an applicable monitor station.	Check station number of target monitor in screen data.
322	Specified device is outside range.	The number of the device to be monitored is outside the permissible range of the applicable PC CPU.	Set device in the permissible monitoring range by setting parameter and PC CPU to be monitored.
323	Specified file register is outside range.		
330	Memory card capacity is insufficient.	Memory card capacity is insufficient.	Check capacity.
331	Memory card is not mounted or M-CARD switch is OFF.	Memory card is not mounted or the memory card access switch has turned OFF.	Mount memory card and/or turn access switch to ON.
332	Format error	Memory card is not formatted.	Format memory card.

Error code	Error message	Error contents	Remedy
333	Write not possible because memory card is write protected.	Memory card is write protected.	Cancel write protection of memory card.
334	Memory card is faulty.	Memory card is defective.	Replace memory card.
335	Memory card battery voltage is low.	Memory card battery voltage has dropped.	Replace memory card battery.
340	Error generated by printer or power is disconnected.	Printer is faulty, or printer power supply is not engaged.	Check printer and/or engage printer power supply.
341	Printer is faulty.		
350	RS-232C communication error	Cable connecting GOT to personal computer is faulty.	Check for loose connectors of communications cable and check cable in use.

12. System Configurations When Making Bus Connections

In addition to bus connections, the following are also possible: MELSECNET connections, calculator link module connections, and direct connection to a CPU. The bus connection offers the fastest PC CPU response speed.

With bus connections, expansion connectors are used to connect the main base and the expansion base to the GOT. If a large-sized PC CPU is connected, the GOT can be installed up to 36.6 m (120 feet) from the main base. With a smaller PC CPU, the GOT can be installed as far as 30 m (98 feet) from the main base.

In addition, up to three GOT modules can be connected to a single PC CPU. (There may be times when only two GOT modules can be connected, depending on the type of PC CPU.)

Connecting to a small-sized PC CPU

(1) Connecting one GOT

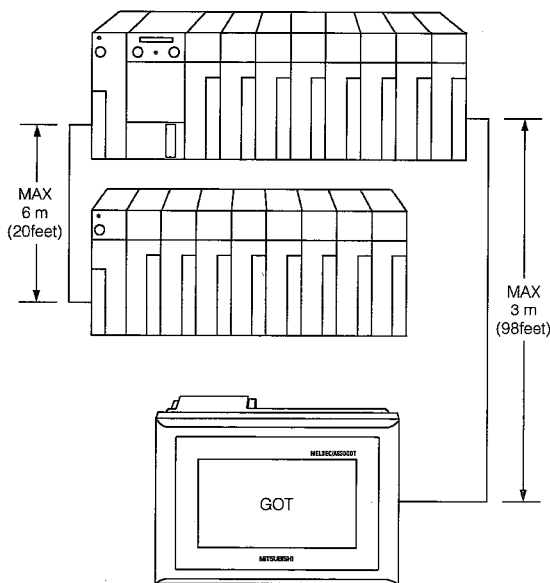

(2) Connecting several GOT modules

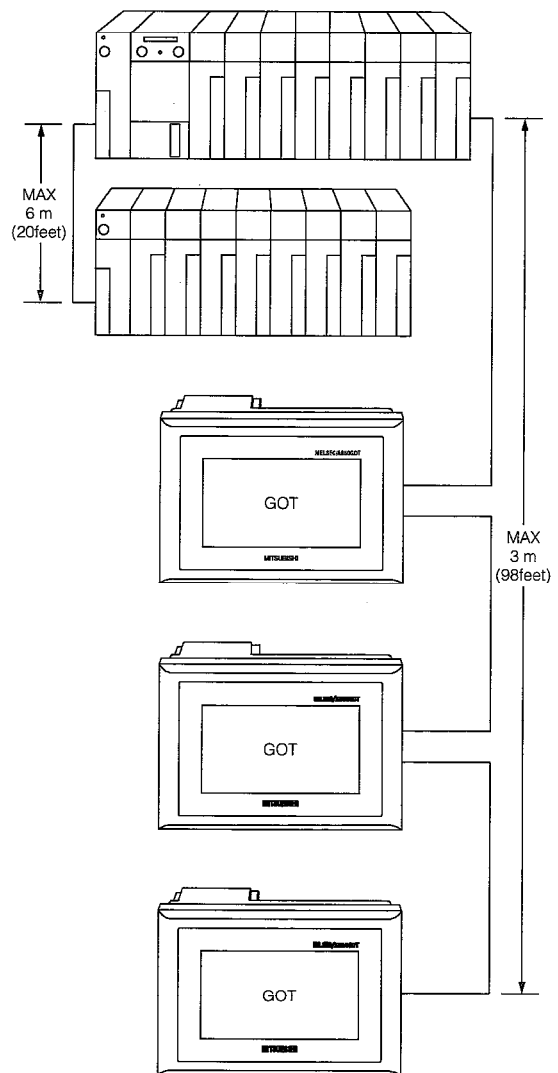

Connecting to a large-sized PC CPU

(1) Connecting a GOT within 6.6 m (22 feet)

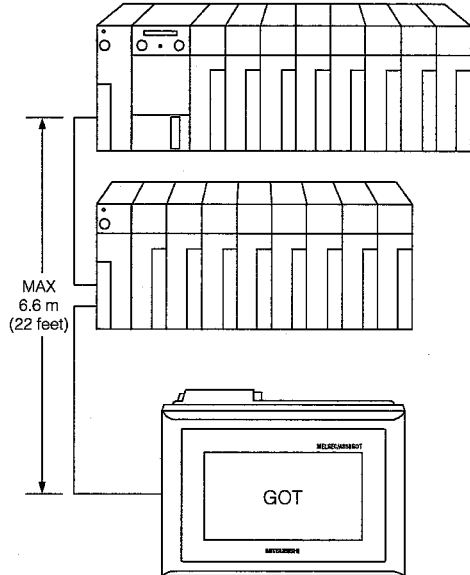

(3) Connecting several GOT modules

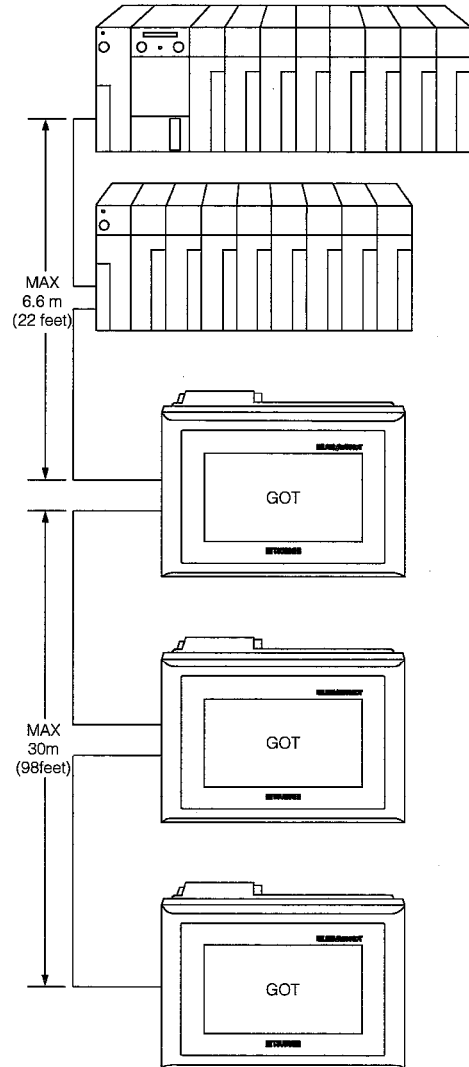

(2) Connecting a GOT at more than 6.6 m (22 feet)

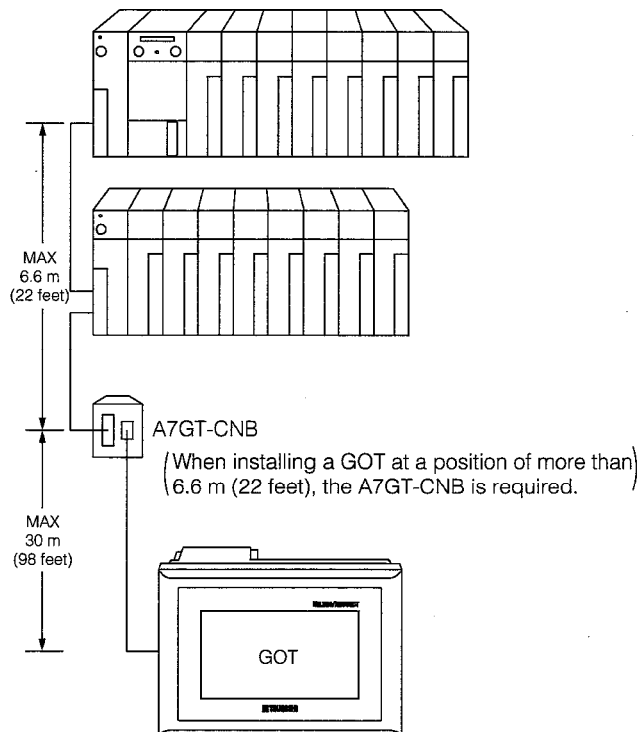

When 3 GOT modules are being connected, the first one must always be positioned within 6.6 m(22 feet)

12.1 Useful Information When Making Bus Connections

12.1.1 PC CPU handling of the GOT with bus connections

When using a bus connection, the PC CPU recognizes the GOT as a special function module with 32 I/O points. For this reason, when one GOT is connected, there must always be one empty I/O slot (32 empty points) on the expansion base module.

When connecting two GOT modules, there must be two empty slots (64 empty points), and when connecting three GOT modules, 3 slots are required (96 empty points).

Even if there are no empty I/O slots, however, the GOT can be connected and used through a bus connection if the number of empty points listed below are available.

Connecting 1 GOT 32 points

Connecting 2 GOTs 64 points

Connecting 3 GOTs 96 points

12.1.2 Restrictions when using a direct PC CPU connection

If a direct I/O control is being used with the CPU connected to the GOT, the empty slot input X cannot be used when the GOT is connected as described below.

- When a 5 m (16 feet) expansion cable (AC50B (-R), A1SC50NB) is used to connect one GOT to the main/expansion base unit.

The above restrictions do not apply if the refresh method is being used for I/O control.

With a PC CPU in which the I/O control method can be changed using a switch, the method should be set to the refresh method.

When input X of the empty slot is being used

- 1) When input X has been assigned with the MELSECNET (II, /B) data link or MELSECNET/10 network
- 2) When the data received from the MELSECNET/MINI-S3 data link is read to the FROM command input X
- 3) When input X of the empty slot is turned on and off from the calculator link unit
- 4) When input X of the empty slot is turned on and off using a touch switch function (bit SET/RST, alternate, momentary) of the GOT

12.1.3 Restrictions on the number of GOTs connected to a PC CPU

When using a bus connection, there are some restrictions on the number of GOTs that can be connected, depending on the PC CPU to which the GOTs are connected, and the number of special function modules installed.

	Q□ACPU	A□ACPU, A□UCPU, A2USCPU	Other CPU
No. of GOTs which can be connected	Up to 3	Up to 3	Up to 2
No. of GOTs + special function modules which can be installed	No limit for GOT and special function modules listed in *1. Up to 6 altogether can be installed, including GOT and special function modules listed in *2.	Up to 6 altogether, including GOTs and the *2 special function modules	Up to 2 altogether, including GOTs and the *2 special function modules

*1. Special function modules of the following models:

AJ71QC24 (R2/R4)

*2. Special function modules of the following models:

AD51(S3), AD51H(S3), AD51FD(S3), AD57G(S3), AJ71C21(S1), AJ71C23,
AJ71C24(S3/S6/S8), AJ71E71, AJ71C22(S7), AJ71UC24, A1SJ71UC24(R2/PRF/R4),
A1SJ71E71

12.1.4 Supplying power to the PC CPU and the GOT

When supplying power to the PC CPU and the GOT, please observe the precautions noted below.

(1) Always use one of the procedures below to turn on the power supply to the PC CPU and GOT. One of these procedures should be used even if several GOTs are connected to the CPU.

- ① Turn on the power supply to the PC CPU and the GOT at the same time.
- ② Turn on the power supply to the PC CPU first, and then to the GOT.

If several GOTs have been connected, and the power supplies are being turned on one by one, the power supplies may be turned on in any order.

(2) If the power supply is turned on using method ② above, the CPU begins to run when the power supply to the GOT is turned on. If several GOTs have been connected, turning on the power supplies to all of the GOTs runs the CPU.

(3) When power is being supplied to the PC CPU and the GOT, turning off the power supply to the PC CPU causes a communications error.

If this happens, turn off the power supply to the GOT and follow procedure (1) above to turn on the power supplies to the PC CPU and the GOT.

(4) The PC CPU continues to run even if the power supply to the GOT is turned off during monitoring.



CAUTION

- When disconnecting the expansion cable that connects the PC CPU and the GOT, to prevent errors from occurring, make sure the power supplies to the PC CPU and the GOT are turned off first.

12.1.5 Resetting the hardware with a bus connection

When connecting buses to GOT, hardware cannot be reset even if the reset switch on the back of the GOT main module is depressed, except after the operations shown below have been performed with utility function.

During bus connection, execute GOT boot up again (power supply: OFF → ON) to reset hardware.

When hardware can be reset by pressing the reset switch

- After language switchover operation (Japanese/English switchover)
- After changing settings of setup function and terminating utility screen
- After performing user area check of the self-diagnosis function and terminating utility screen

12.1.6 Precautions when using the A7GT-BUS

There are hardware versions of the A7GT-BUS that cannot be used for the connected CPU and GOT installation distances, so take due caution.

A7GT-BUS installing position	Distance from PC CPU	Connected CPU	Hardware versions of the A7GT-BUS that can be used.
1st machine	Installed within the extension overall distance limitations.	Q4ARCPU	Versions C and later can be used. Versions A and B cannot be used.
		MELSEC-QnA series CPUs other than Q4ARCPU	Versions B and later can be used. Version A cannot be used.
		A0J2HCPU	Versions C and later can be used. Versions A and B cannot be used.
		MELSEC-A series CPUs other than A0J2HCPU	Versions A and later can be used. Versions B and later can be used. Version A cannot be used.
2nd machine 3rd machine	Installed without the extension overall distance limitations.	Version C and later can be used and versions A and B cannot be used regardless of the connected CPU or GOT.	
	Installed within the extension overall distance limitations.		
	Installed without the extension overall distance limitations.		

The hardware version can be checked to see if it is a A7GT-BUS main module back rated hardware version.

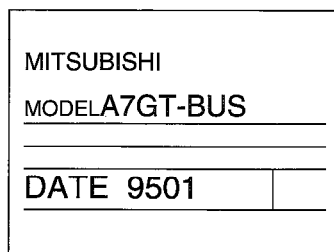

Modules for which there is no version written in the DATE column are hardware version A.

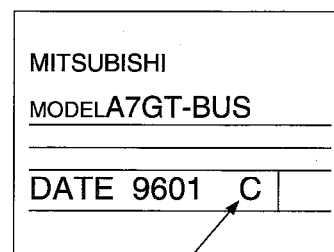

The letter indicated by the arrow of the DATE column is the hardware version.

12.2 Switch Settings for a Bus Connection Module

When using a bus connection, the GOT must be assigned to one of the empty I/O slots in the expansion base module. The assignment is made using the expansion stage switch and the I/O slot switch on the left side of the bus connection module to which the GOT is connected.

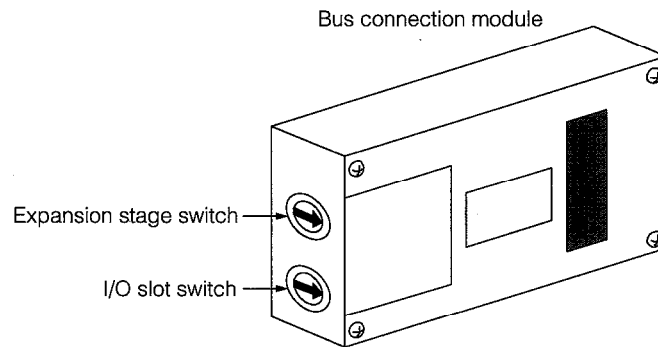

Expansion stage switch

Set the number of expansion stages of the empty I/O slots to which the GOT is assigned.

1 to 7 : Sets the number of expansion stages

0, 8, 9 : Cannot be used

I/O slot switch

Set the number of the empty I/O slot to which the GOT is assigned.

0 to 7 : Sets the number of the I/O slot

8, 9 : Cannot be used

Point

The GOT cannot be assigned to an empty I/O slot on the main base; it must always be assigned to an empty I/O slot on the expansion base.

1 When no expansion base unit is connected

Because the GOT cannot be assigned to an empty I/O slot on the main base, if no expansion base is connected, it must still be assigned to an empty slot in the first expansion stage.

Example of settings

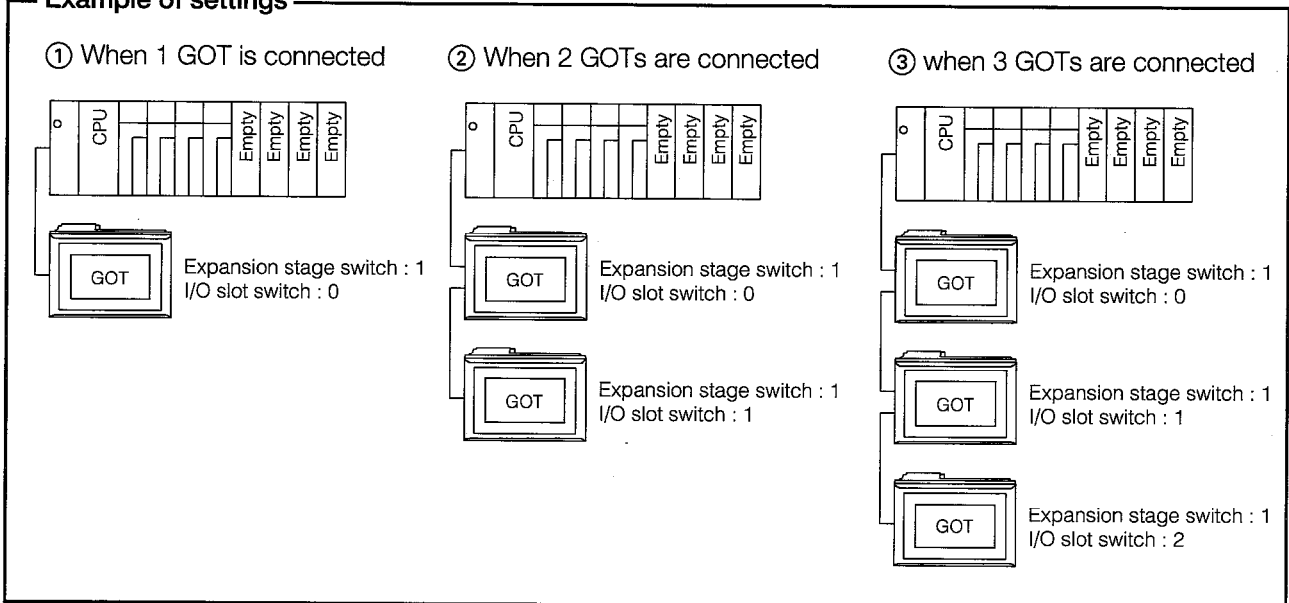

2 Settings when the GOT is assigned to an empty slot in the expansion base module

Specify the expansion stage in the empty slot to which the GOT is to be assigned, and the slot number.

Example of settings

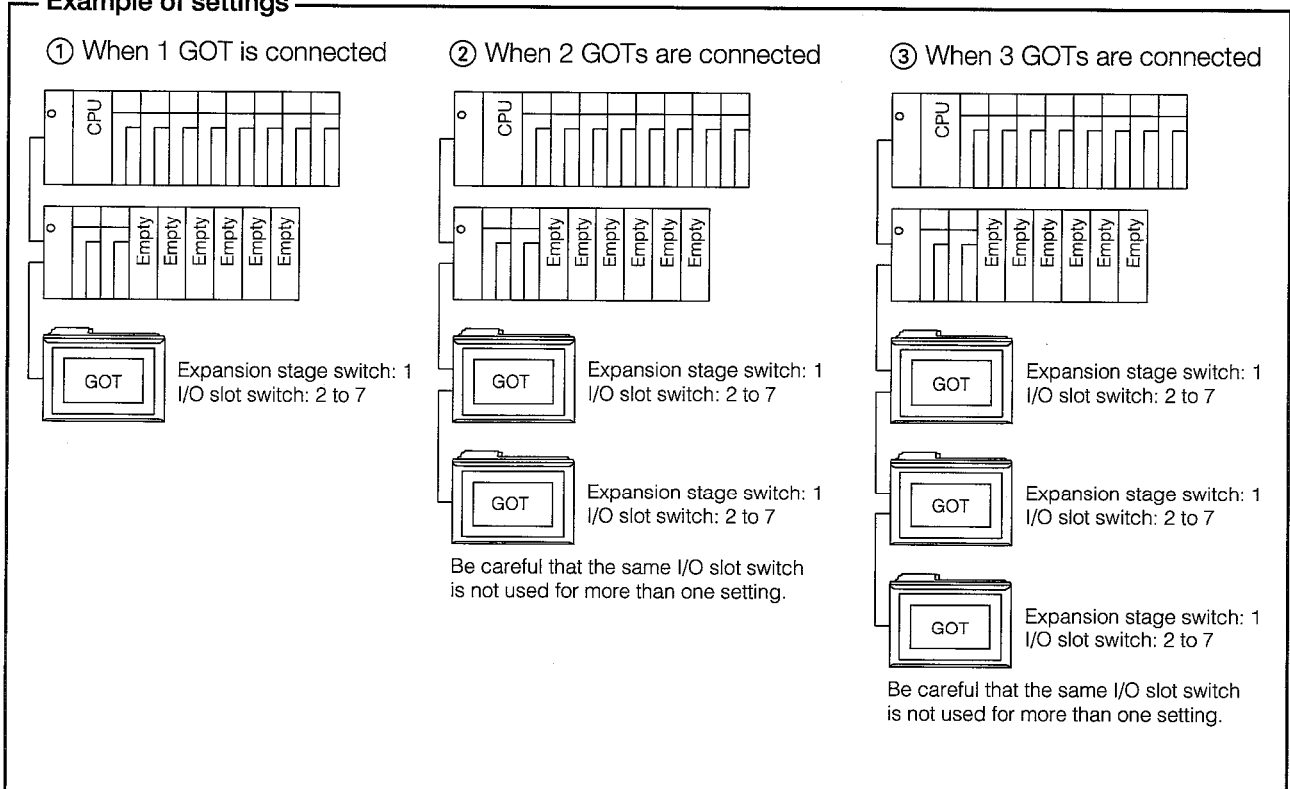

3 When there are no empty I/O slots in the expansion base module to which the GOT is connected

Set the empty slots in the next expansion stage of the expansion base module currently connected to the GOT.

Example of settings

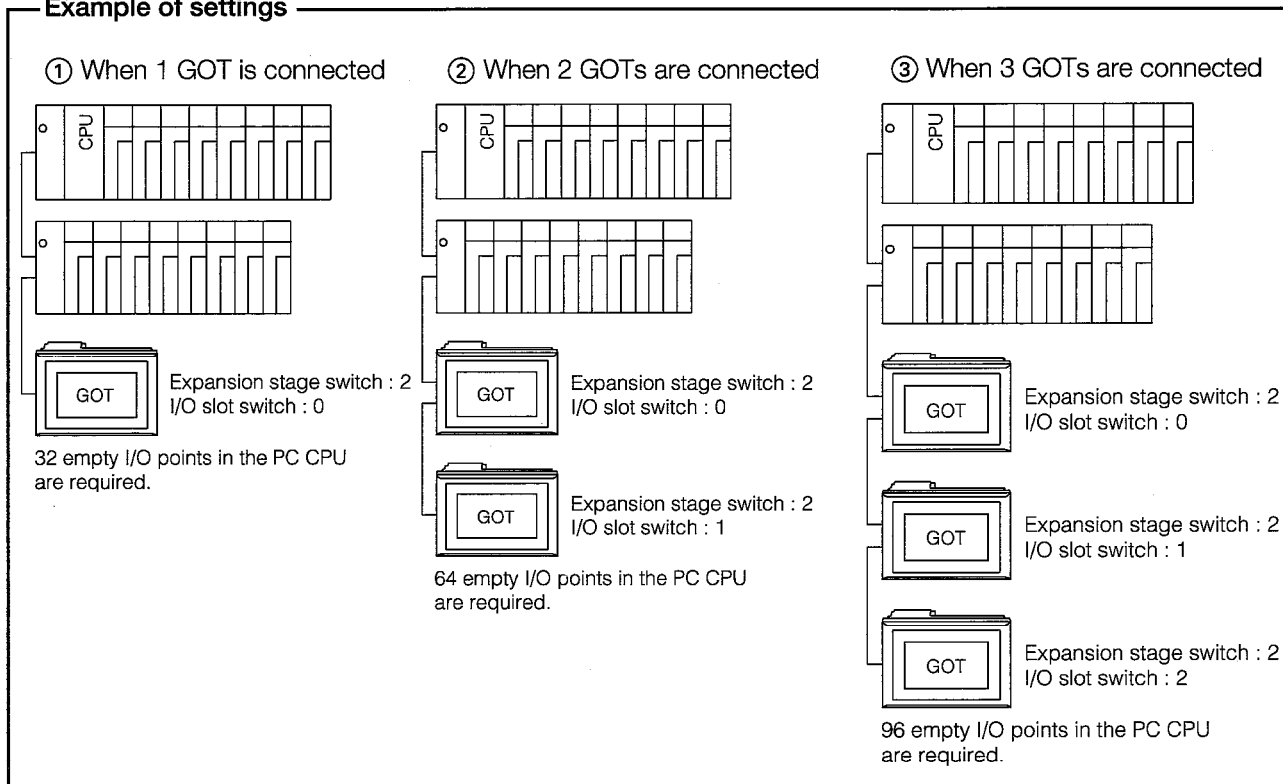

Point

If there are no empty I/O slots in any of the expansion base modules within the maximum range of expansion stages, the expansion stage switch and I/O slot switch should be set as shown above. If the CPU to which the GOT is connected is any of those listed below, however, the above settings cannot be used. There must always be an empty I/O slot in the expansion base module.

- A3□CPU
- A4UCPU
- Q3ACPU
- Q4ACPU
- A0J2HCPU

If the CPU connected to the GOT is the A0J2HCPU, the GOT should be assigned to I/O slot 0 to 3 of the expansion stage module.

12.3 System Configuration When Connecting One GOT Module

12.3.1 When setting GOT within the maximum expansion distance

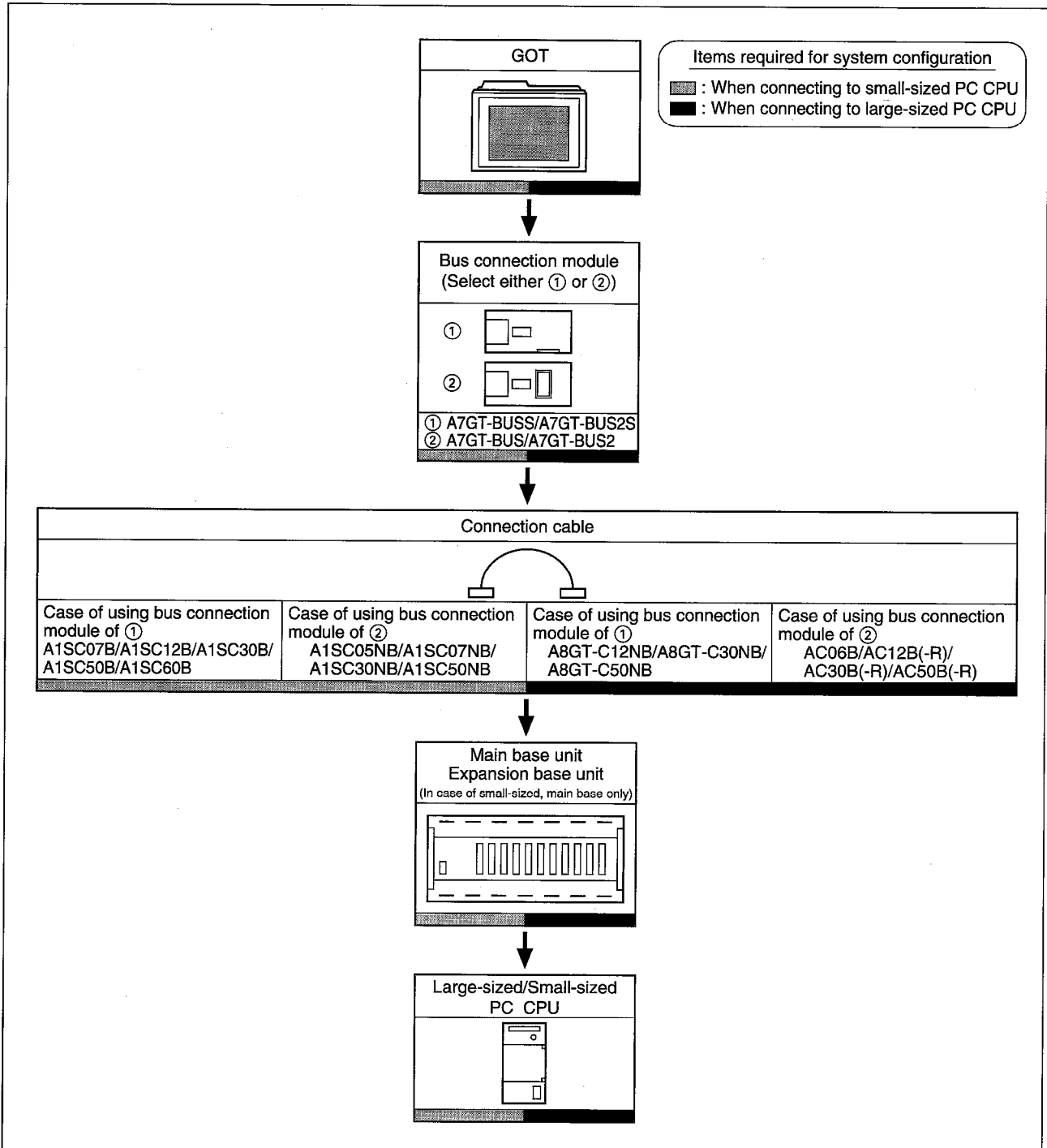

12.3.2 Case of installing GOT at locations beyond the maximum expansion distance

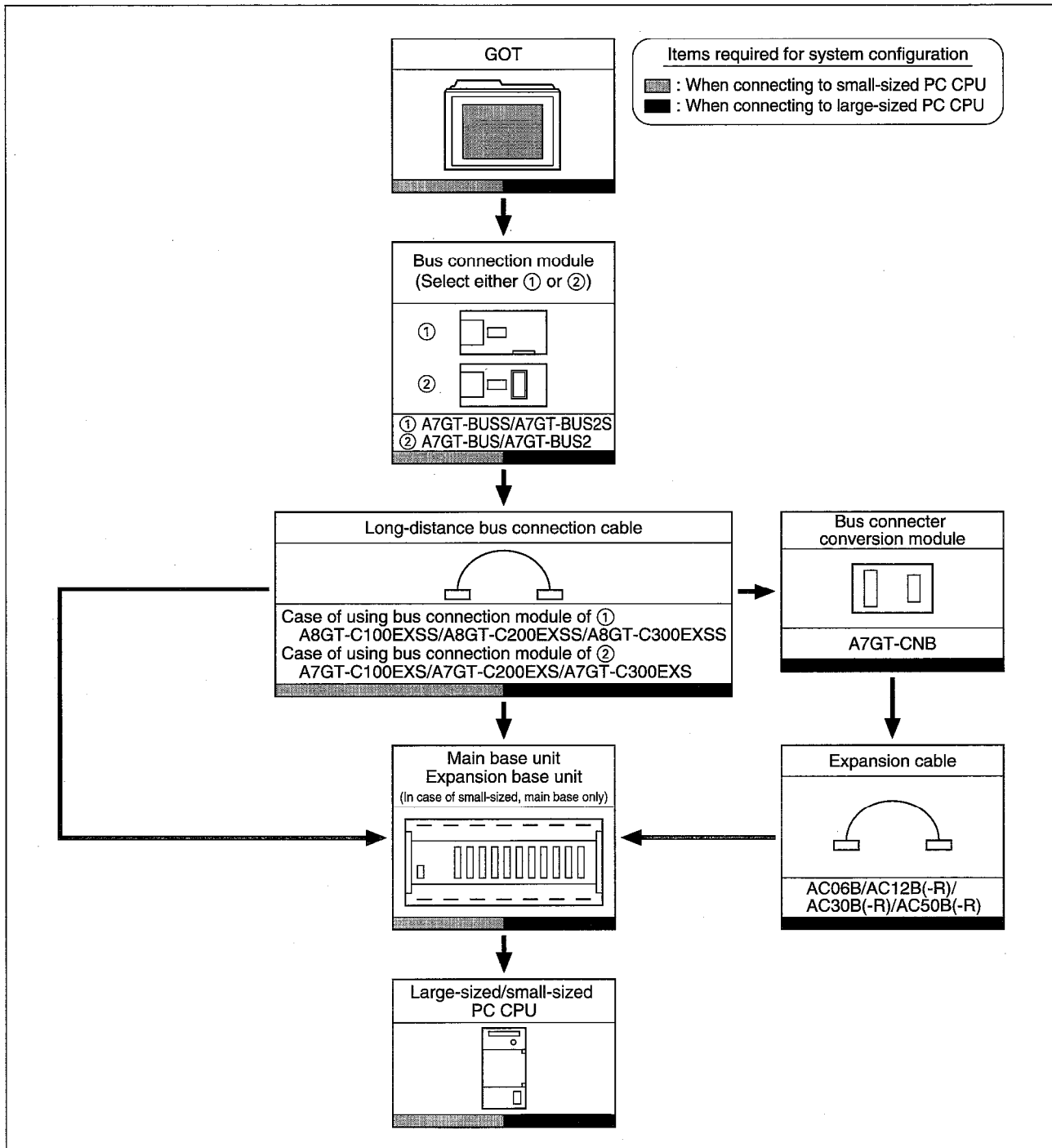

12.4 System Configuration When Connecting Two GOT Modules

12.4.1 When connecting to large-sized PC CPU

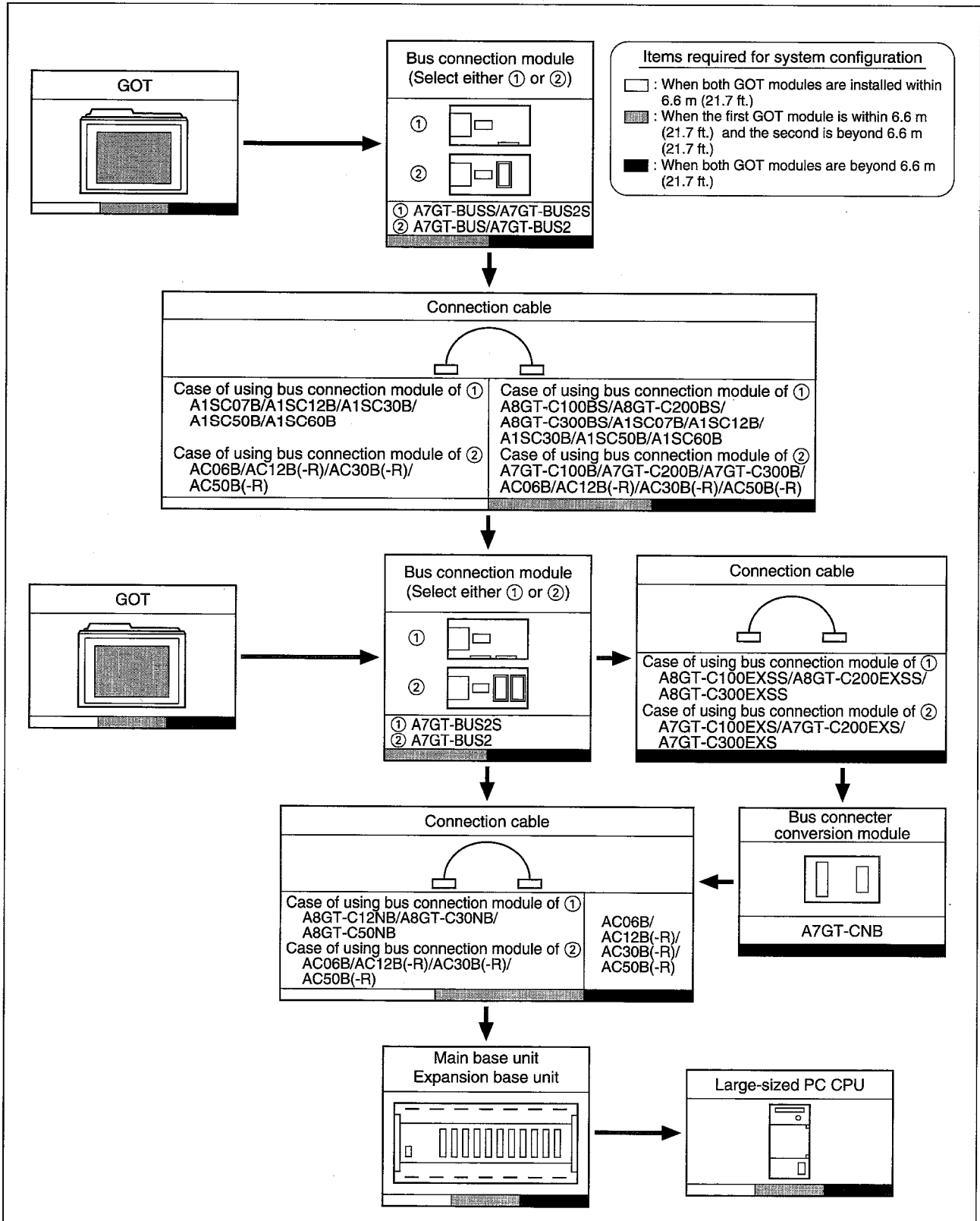

12.4.2 When connecting to small-sized PC CPU

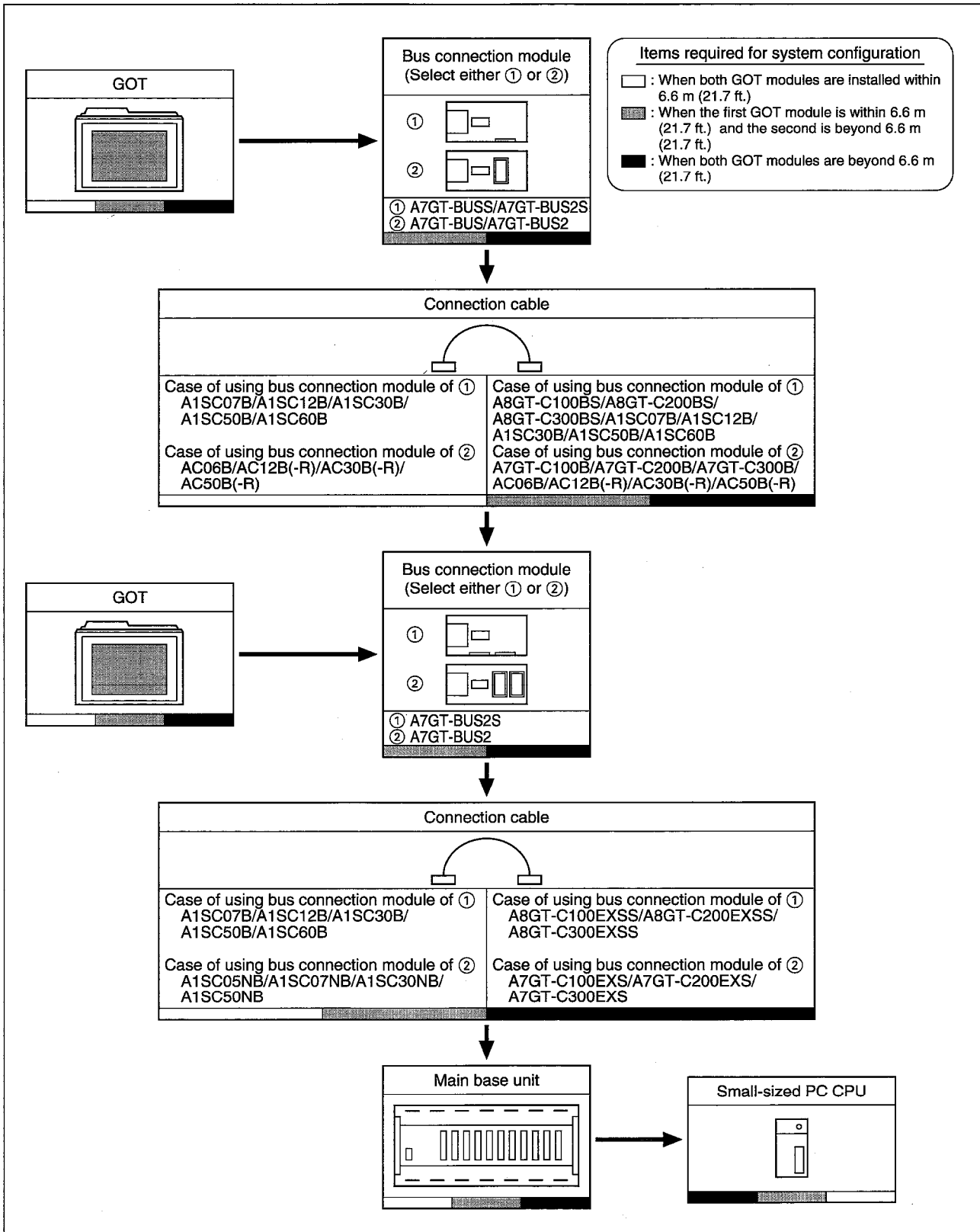

12.5 System Configuration When Connecting Three GOT Modules

When connecting three GOT modules, observe the following.

- Be sure to set the first GOT module within the maximum expansion distance.
- Please note that there are cases in which three GOT modules cannot be connected, depending on the applicable PC CPU or the GOT. (Refer to Section 3.1.3)

12.5.1 When connecting to large-sized PC CPU

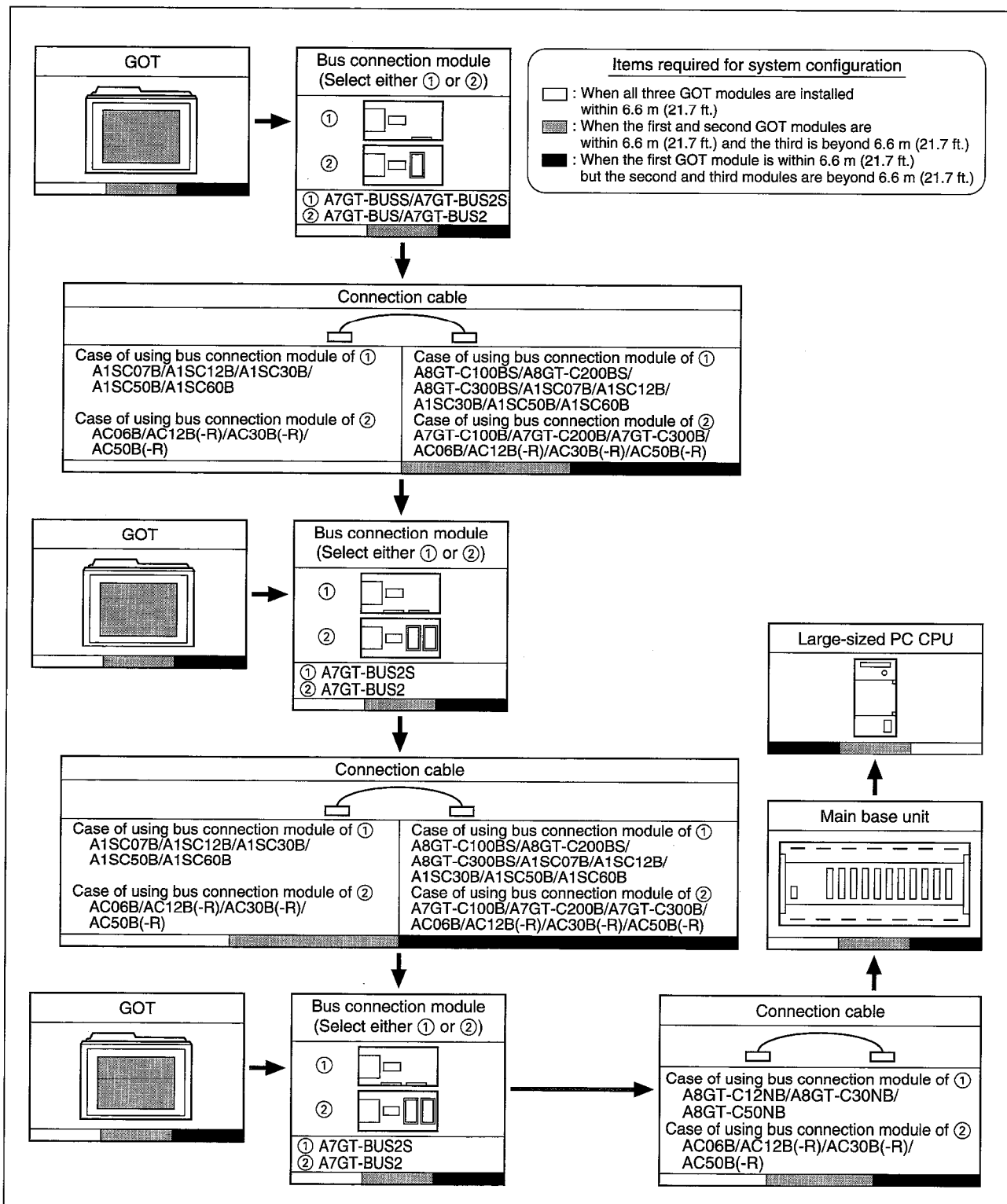

12.5.2 When connecting to small-sized PC CPU

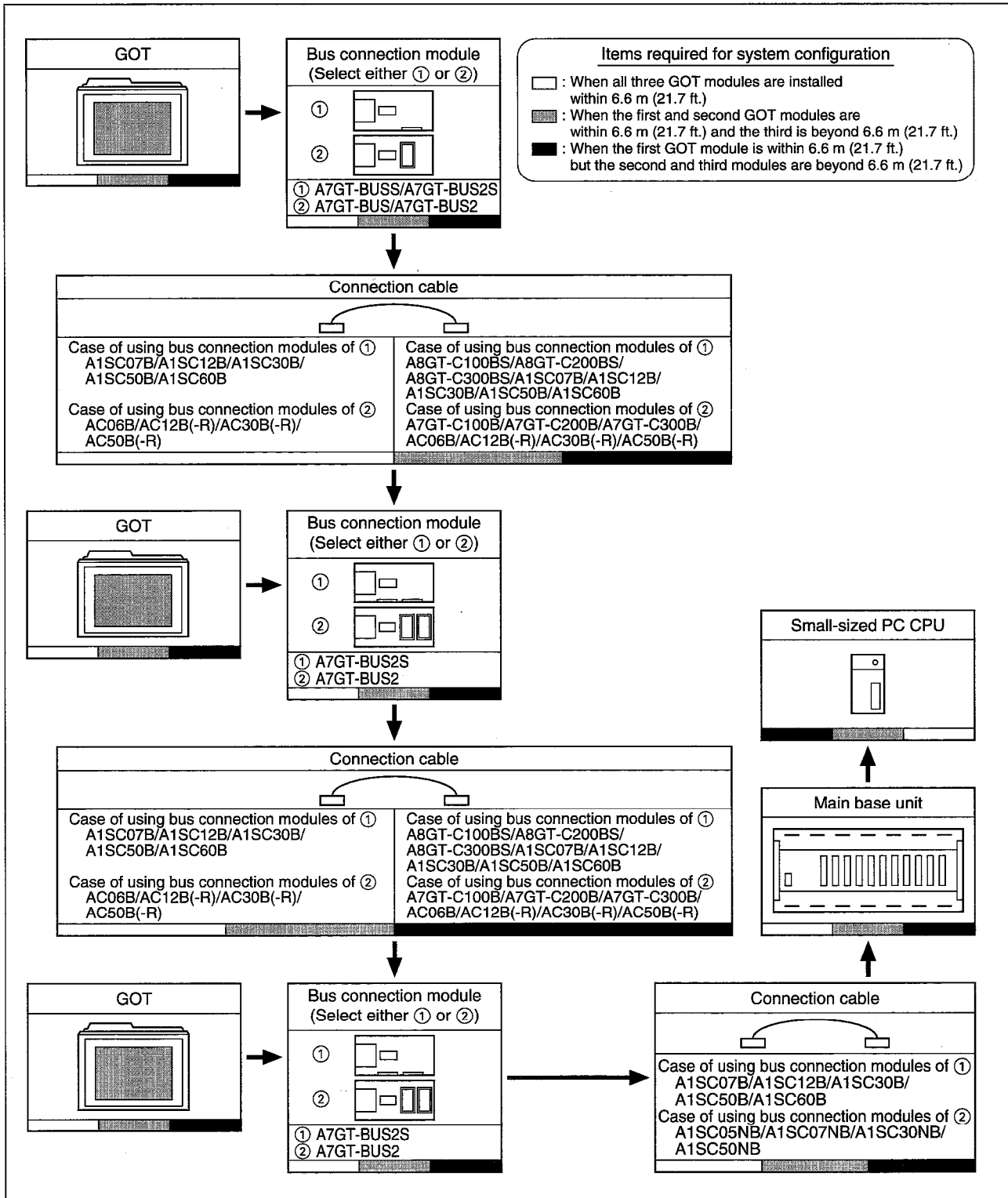

12.6 System Configuration during Bus Connection with A0J2HCPU

When connecting the bus with the A0J2HCPU the A7GT-BUSSS and A7GT-BU2S cannot be used.

12.6.1 System configuration with connection of one GOT module

1 When expansion base unit is not used

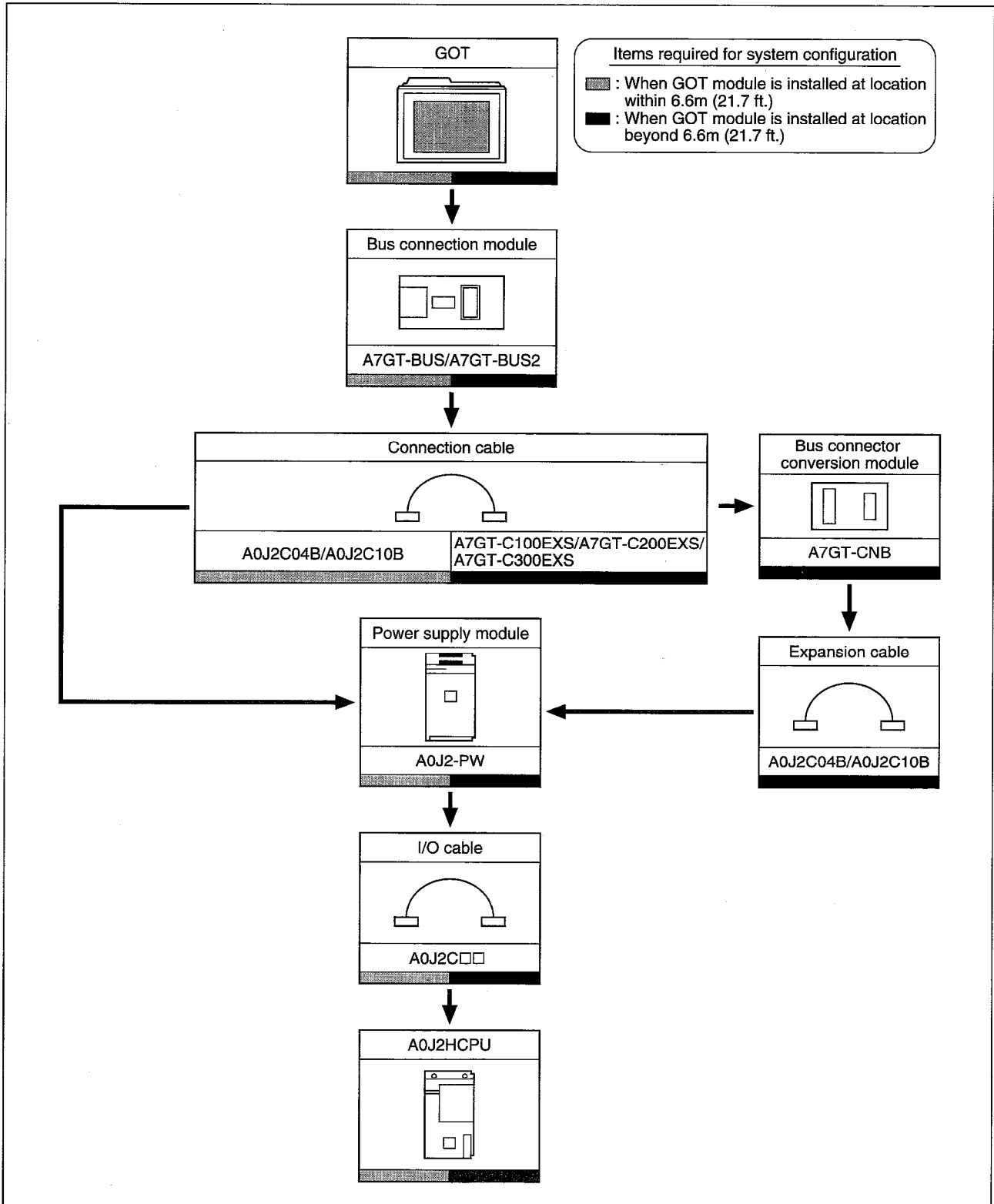

2 When expansion base unit is used

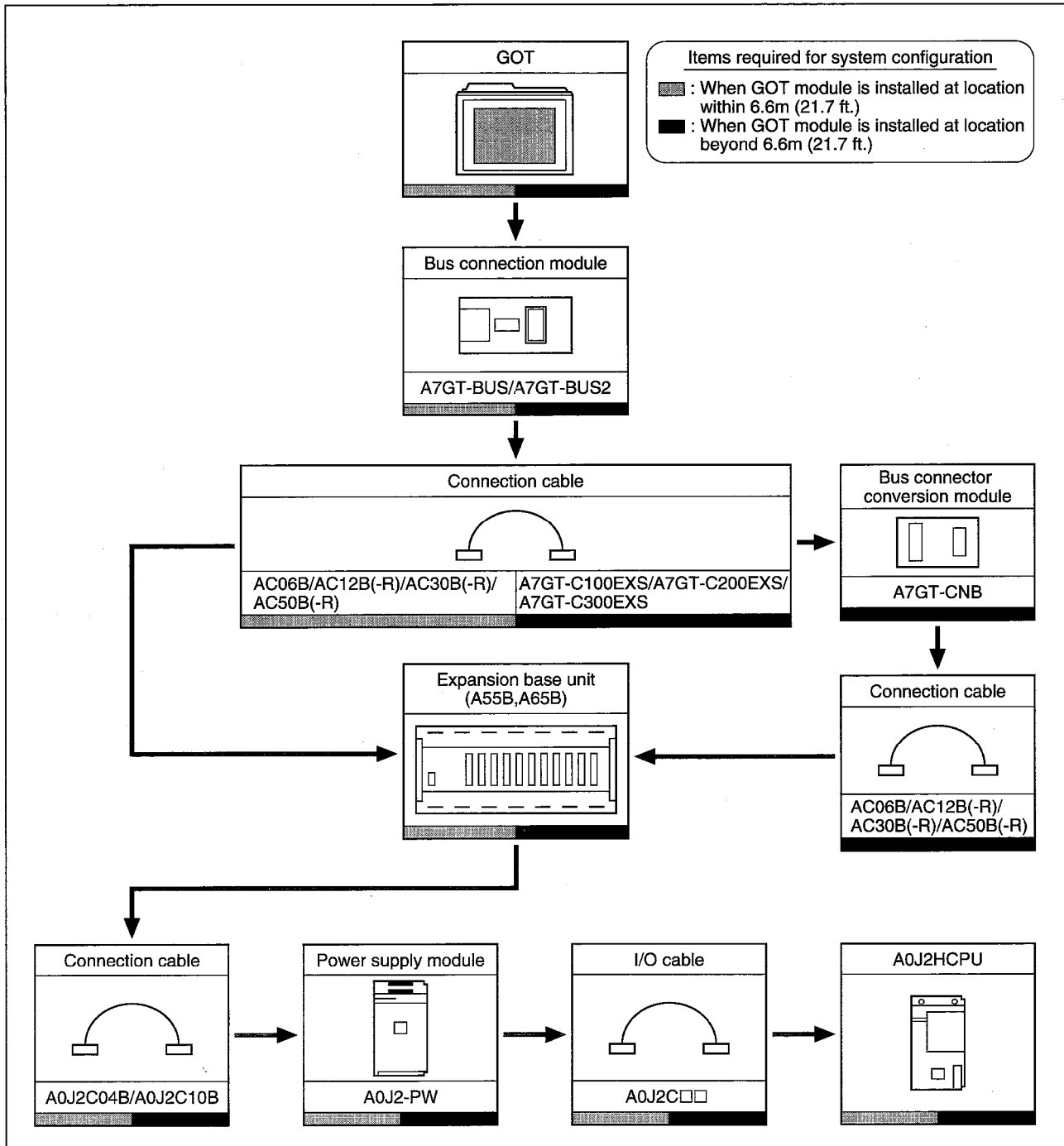

12.6.2 System configuration with connection of two GOT modules

1 When expansion base unit is not used

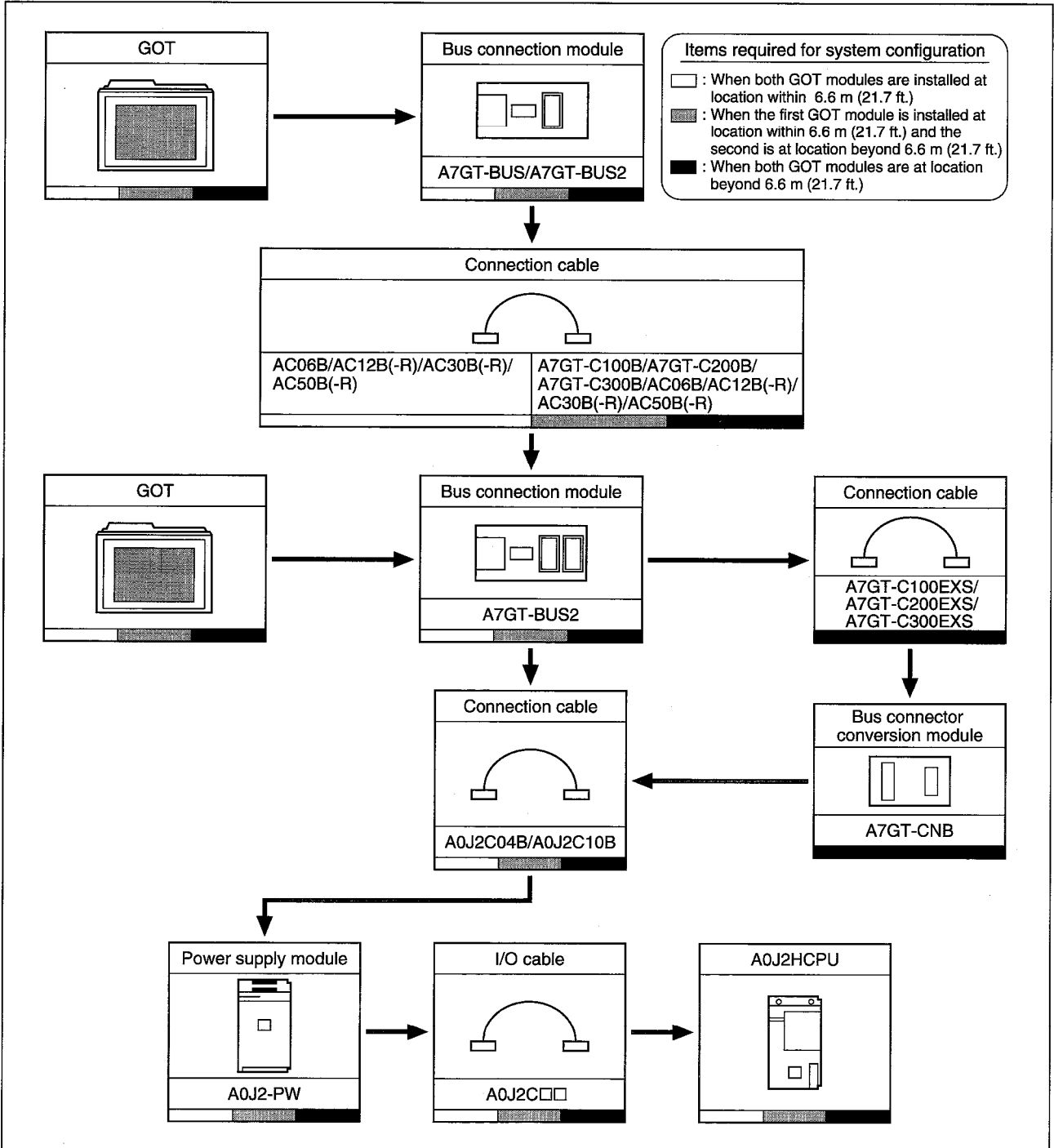

2 When expansion base unit is used

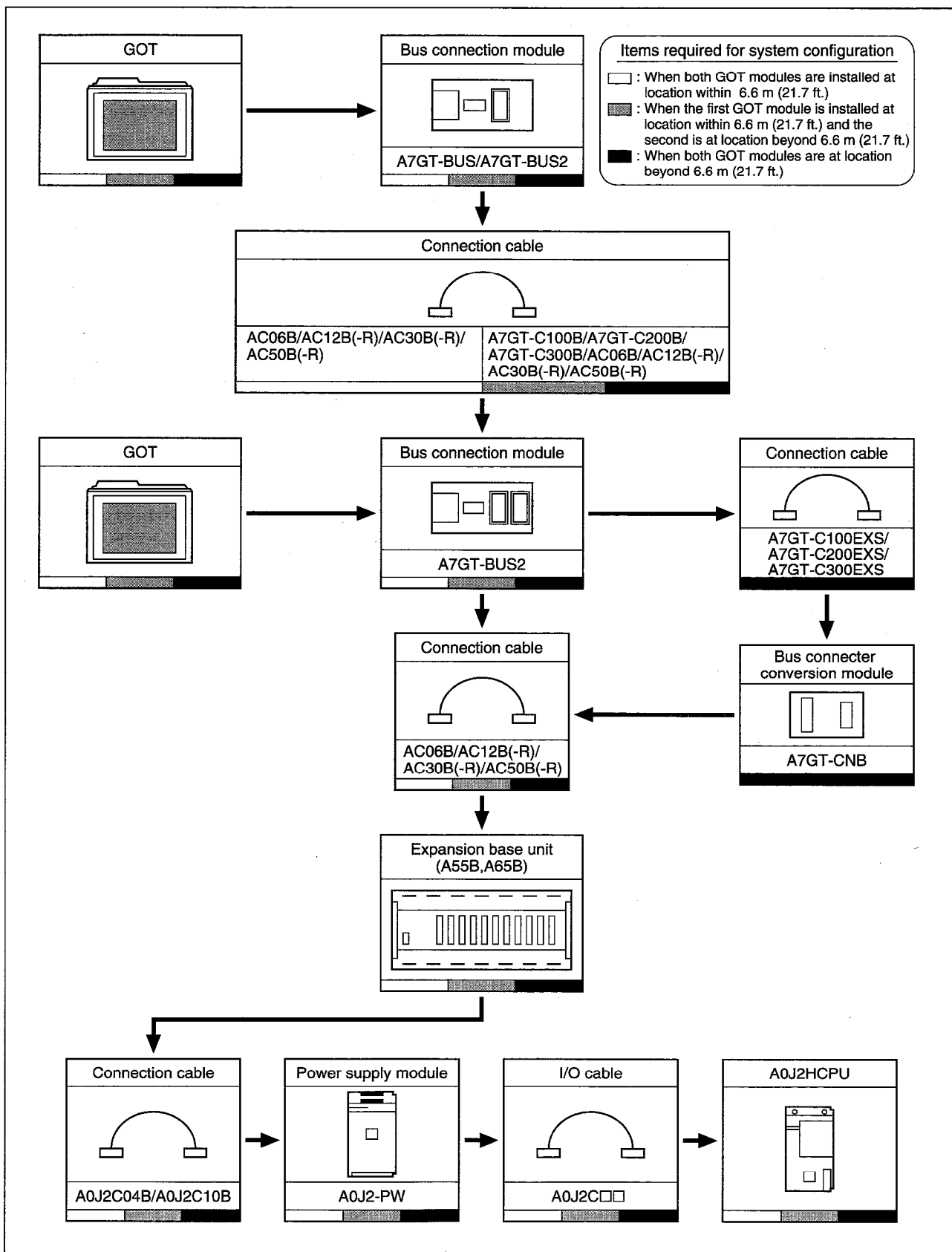

12.7 Differences between A7GT-BUS BUS2 and A7GT-BUSS/BUS2S

The differences between A7GT-BUS/BUS/BUS2 and A7GT-BUSS/BUS2S are presented below.

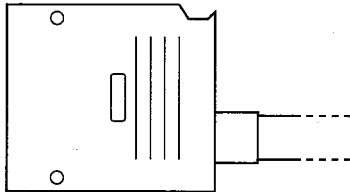
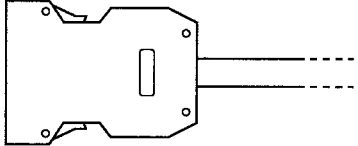
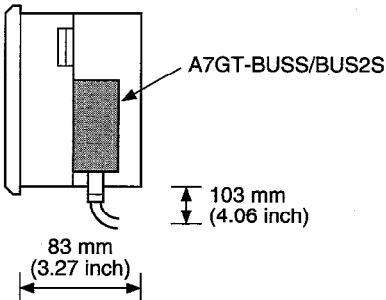
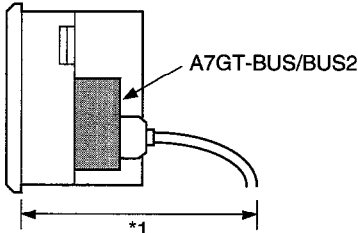
	A7GT-BUS/BUS2	A7GT-BUSS/BUS2S										
Connector size	<p>Large-sized CPU type expansion connector size</p> 	<p>Small-sized CPU type expansion connector size</p> 										
Depth dimensions when the GOT is installed.	<p>GOT side face</p> 	<p>GOT side face</p>  <p>*1 The depth dimension varies depending on the cable that is connected.</p> <table border="1"> <thead> <tr> <th>Cable model name</th> <th>Depth dimension (Unit: mm (inch))</th> </tr> </thead> <tbody> <tr> <td>AC06/12/30/50B</td> <td>210 (8.27)</td> </tr> <tr> <td>A1SC05/07/30/50B</td> <td>190 (7.48)</td> </tr> <tr> <td>A7GT-C100/200/300EXS</td> <td></td> </tr> <tr> <td>AC12/30/50B-R</td> <td>110 (4.33)</td> </tr> </tbody> </table>	Cable model name	Depth dimension (Unit: mm (inch))	AC06/12/30/50B	210 (8.27)	A1SC05/07/30/50B	190 (7.48)	A7GT-C100/200/300EXS		AC12/30/50B-R	110 (4.33)
Cable model name	Depth dimension (Unit: mm (inch))											
AC06/12/30/50B	210 (8.27)											
A1SC05/07/30/50B	190 (7.48)											
A7GT-C100/200/300EXS												
AC12/30/50B-R	110 (4.33)											

Point

Please note that when connecting more than one GOT module through bus connections, A7GT-BUS/BUS2 and A7GT-BUSS/BUS2S cannot be combined and used.

(Example) Case of connecting two GOT modules

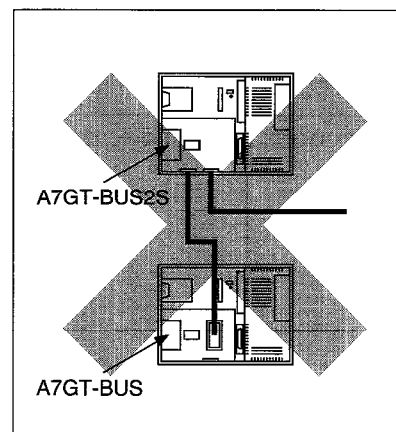
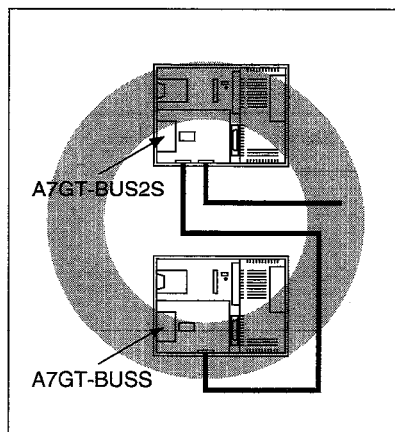

Appendix

Appendix 1. A870GOT External Dimensions Diagram

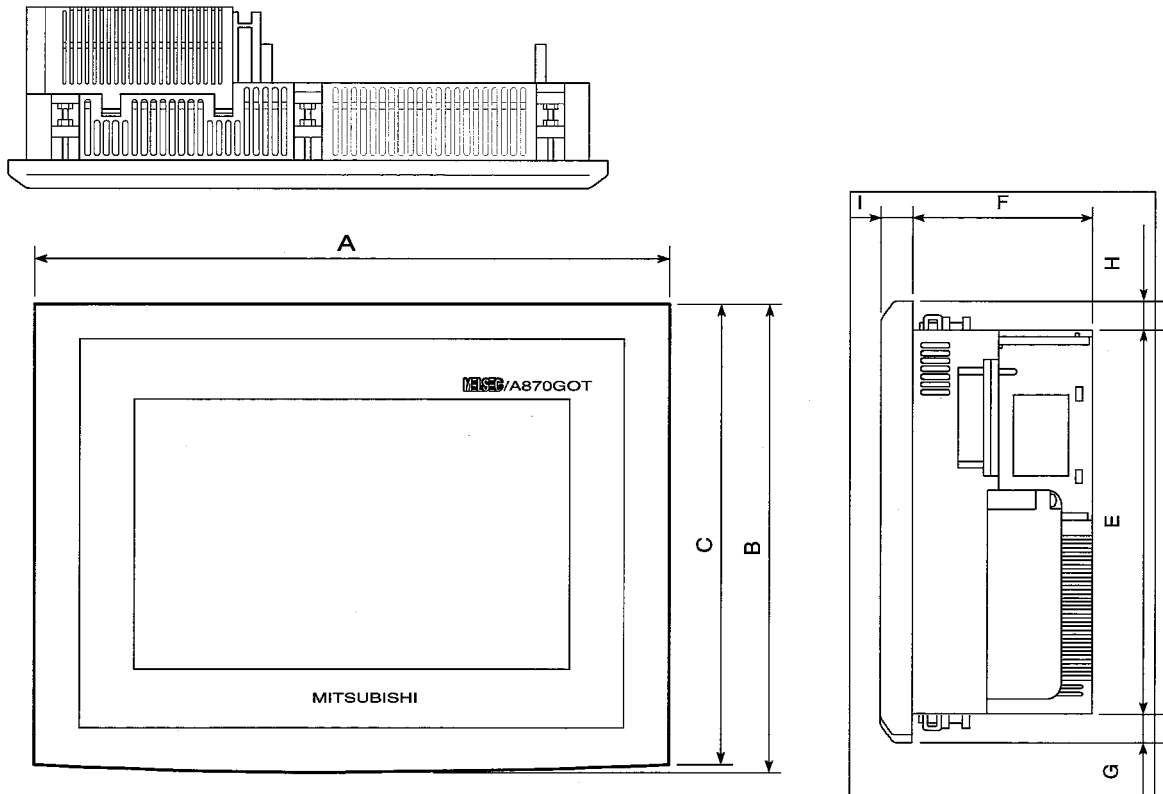

Unit: mm (inch)

Model	A	B	C	D	E	F	G	H	I
A8GT-70GOT-EW A8GT-70GOT-EB	285 (11.2)	209.5 (8.2)	206.5 (8.1)	265 (10.4)	182 (7.2)	83 (3.3)	15 (0.6)	12.5 (0.5)	15 (0.6)
A8GT-70GOT-SW A8GT-70GOT-SB A8GT-70GOT-TW A8GT-70GOT-TB	320 (12.6)	230 (9.1)	226 (8.9)	300 (11.8)	202 (8.0)	81 (3.2)	16 (0.6)	12 (0.5)	15 (0.6)

* With power supply module and communications module installed

Appendix 2. Depth Dimension When Loading Communications Module

(1) When using A7GT-BUS/BUS2

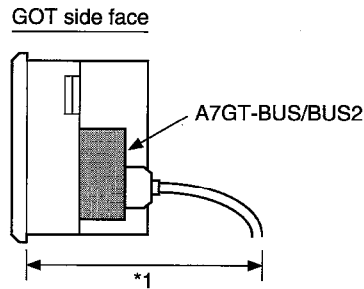

*1 The depth dimension varies depending on the cable that is connected.

Cable model name	Depth dimension (Unit:mm (inch))
AC06/12/30/50B	210 (8.27)
A1SC05/07/30/50B	190 (7.48)
A7GT-C100/200/300EXS	190 (7.48)
AC12/30/50B-R	110 (4.33)

(2) When using A7GT-BUSS/BUS2S

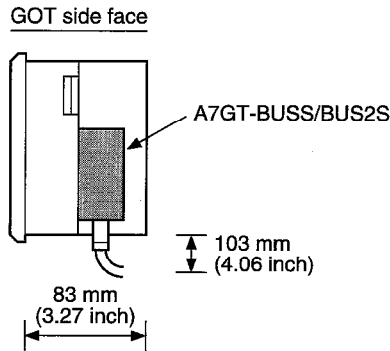

(3) When using A7GT-J71AP23/A7GT-J71LP23

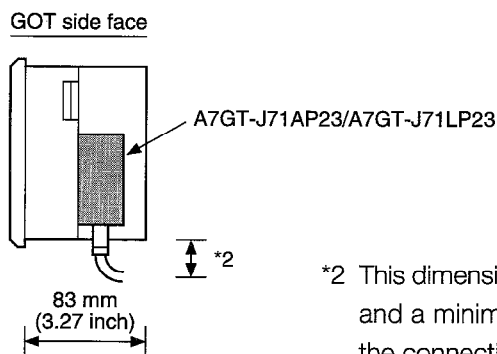

*2 This dimension is at a maximum of 195 mm (7.68 inch) and a minimum of 80 mm (3.15 inch), depending on the connecting optical fiber cable and connector.

(4) When using A7GT-J71AR23/A7GT-J71BR13

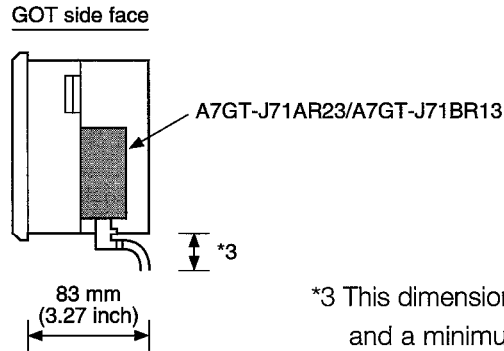

*3 This dimension is at a maximum of 80 mm (3.15 inch) and a minimum of 73 mm (2.87 inch), depending on the connecting coaxial cable.

(5) When using A7GT-J71AT23

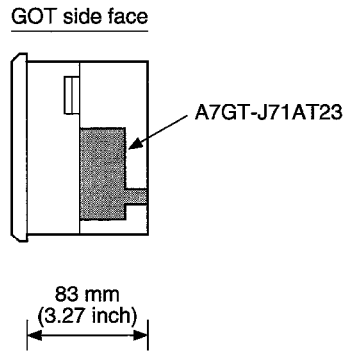

Appendix 3 A8GT-70PRF External Dimensions Diagram

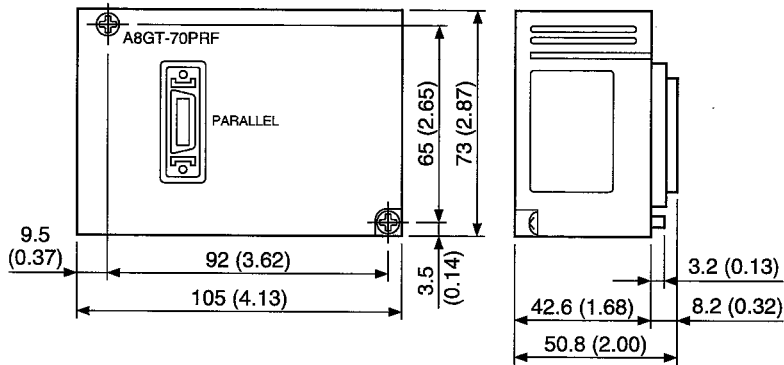

Unit: mm (inch)

Appendix 4 A7GT-CNB External Dimensions Diagram

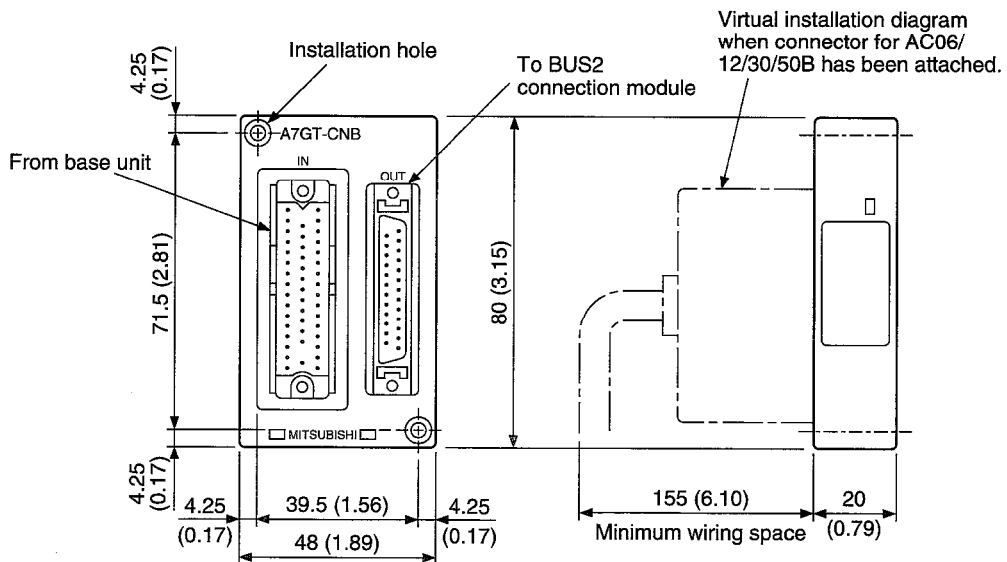

Unit: mm (inch)

Appendix 5 A8GT-70KBF External Dimensions Diagram

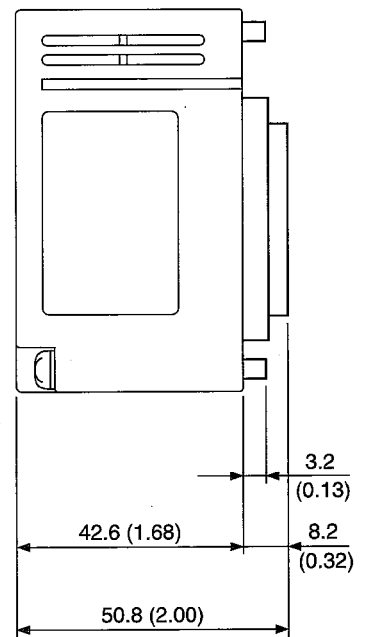
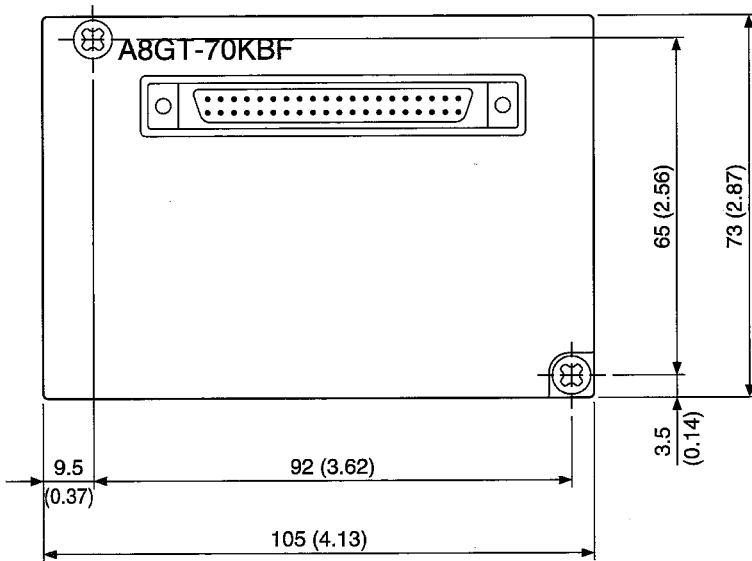
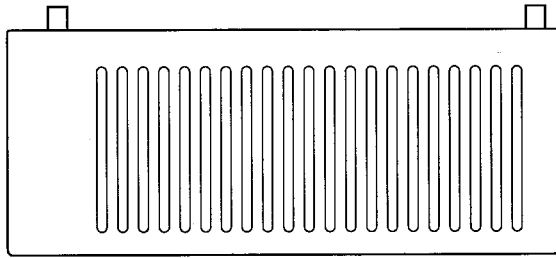

Unit: mm (inch)

A870GOT Graphic Operation Terminal

User's Manual

MODEL	A870GOT-U-E
MODEL CODE	13J830
IB(NA)66628-D(9801)MEE	



HEAD OFFICE : MITSUBISHI DENKI BLDG MARUNOUCHI TOKYO 100-0005 TELEX : J24532 CABLE MELCO TOKYO
NAGOYA WORKS : 1-14 , YADA-MINAMI 5 , HIGASHI-KU, NAGOYA , JAPAN

When exported from Japan, this manual does not require application to the Ministry of International Trade and Industry for service transaction permission.

Specifications subject to change without notice.